

BOOK No. 100/F.W.2A

DRIVER'S HANDBOOK

FOR

TRACTOR, 4 x 4 MEDIUM

A.E.C. "MATADOR"

Model 0853—C.I. Engine

(Air Pressure Assisted Hydraulic Brakes)



October, 1943.

BOOK No. 100/F.W.2A.

DRIVER'S HANDBOOK

FOR

TRACTOR, 4 x 4 MEDIUM

A. E. C. "MATADOR"

Model 0853—C.I. Engine

(Air Pressure Assisted Hydraulic Brakes).

THE ASSOCIATED EQUIPMENT CO. LTD.

October, 1943.

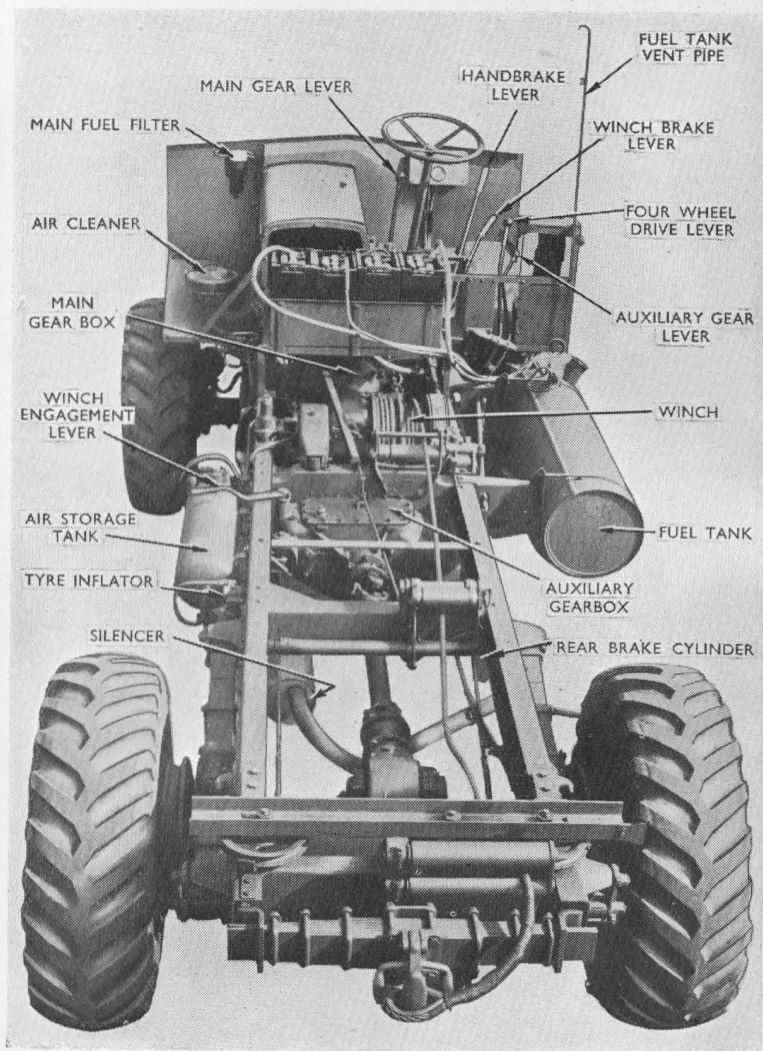

Fig. 1. Arrangement of Chassis.

TO DRIVERS.

THIS BOOKLET is to assist you in carrying out your duties of driving and maintaining the A.E.C. "Matador" 4 x 4 Medium Tractor. While every care has been taken in the design and manufacture of the vehicle to obtain maximum mileage between overhauls, certain adjustments and periodical lubrication are essential to obtain this mileage. To this end, routine maintenance is divided into 16 simple tasks, which must be carried out regularly in sequence so that all the tasks are completed once per fortnight. **Apart from necessary adjustments and lubrication, a vehicle that is performing satisfactorily should not be tampered with or any part dismantled, as this may lead to trouble.** See to it that you understand the tasks and your vehicle, and should you notice anything which may be wrong during your inspection, report it. **Do not overlook anything.**

If your vehicle is equipped with **air pressure braking equipment instead of Hydraulic**, you should ask for Driver's Handbook No. 100/FW1 or 100/FW3. Hydraulic brakes may be identified by the servo motor mounted inside the O.S. chassis member; air pressure brakes are not fitted with a servo motor.

CONTENTS.

	<i>Page</i>
General Data	5
Controls	7
Starting and Driving Instructions	11
Frost Precautions	16
Instructions for using the Winch	19
Periodical Attention (<i>items not covered by the Tasks</i>)	22
Routine Maintenance (<i>Sixteen Tasks</i>)	25
Task No. 1—Engine	26
Task No. 2—Engine Lubrication	28
Task No. 3—Engine Cooling System	30
Task No. 4—Fuel Supply System	31
Task No. 5—Engine Controls	35
Task No. 6— { These Tasks do not apply to this vehicle	
Task No. 7— { they are replaced by—Winch.	36
Task No. 8—Steering	37
Task No. 9—Charging System (Electrical)	38
Task No. 10—Starter Motor and Lights	39
Task No. 11—Clutch and Gearboxes	39
Task No. 12—Transmission Universal Joints and Axles	42
Task No. 13—Chassis and Road Springs	44
Task No. 14—Body	45
Task No. 15—Brake System	46
Task No. 16—Tyres and Tools	54
Special Tools	55
Running Faults and General Hints	57
Lubrication Chart	Inside rear cover

GENERAL DATA.

5

Vehicle designation	Tractor, 4 x 4 Medium A.E.C. "Matador."
Engine	A.E.C. 6-cylinder C.I. Engine.
Oil pressure (<i>gauge on dash</i>)	60 lb./sq. inch at maximum governed speed (1,800 R.P.M.)
Engine Cooling System	6 gallons, when using water, or 1 in. below level of top rim of strainer when using anti-freeze mixture.
Fuel Tank	Capacity 40 gallons. 34 gallons in main tank, 6-gallons in reserve compartment. Main tank measured by gauge on side. Reserve Tank measured by observation through filling hole.
Electrical System	Lighting and auxiliaries 12-volts. Dynamo and starter motor 24-volts. No ammeter fitted; warning light on electrical control unit goes out when dynamo is charging.
Batteries	Four 6-volt units connected in series to supply 24-volts for starting and 12-volts for lighting and auxiliaries. Electrolyte to be $\frac{1}{4}$ in. above top of plates.
Brakes	Lockheed Hydraulic assisted by Air Pressure. Separate cylinder to each road wheel.
Air pressure (<i>gauge on dash</i>)	80-90 lb./sq. inch (Westinghouse). 95-100 lb./sq. inch (Clayton-Dewandre).
Tyres	Size—13.50 in. x 20 in. Single low pressure Bar tread.

LUBRICANTS AND CAPACITIES FOR MAIN UNITS.

Unit.	Service Type Lubricant.	Capacity.
Engine	Oil 30 H.D.	6 gallons.
Fuel-injection pump	Oil 30 H.D.	$\frac{1}{2}$ pint.
Fuel-injection pump governor	Oil 30 H.D.	$\frac{1}{4}$ pint.
Main gearbox	Oil C. 600	1 $\frac{3}{4}$ gallons.
Auxiliary gearbox	Oil C. 600	3 $\frac{1}{2}$ gallons.
Front axle	Oil C. 600	1 $\frac{3}{4}$ gallons.
Rear axle (worm and bevel types)	Oil C. 600	1 $\frac{3}{4}$ gallons.
Steering box	Oil C. 600	1 $\frac{1}{2}$ pints.
Oil bath air cleaner	Oil 30 H.D.	$\frac{1}{2}$ pint.
Change-speed box	Oil C. 600	1 pint.
Winch casing	Oil C. 600	$\frac{1}{2}$ gallon.
Air compressor	Oil 30 H.D.	1 $\frac{1}{2}$ pints.
Trailer brake air cylinder	Oil 30 H.D.	$\frac{1}{2}$ pint.
Servo motor (Clayton Dewandre) only	Oil 30 H.D.	$\frac{1}{4}$ pint.

For all chassis points requiring lubrication and for the Service type of lubricant to be used, see Lubrication Chart inside rear cover of this book.

KEY TO INDEX NUMBERS.

1. Accelerator Pedal.
2. Brake Pedal.
3. Clutch Pedal.
4. Hand Brake Lever.
5. Winch Brake Lever.
6. Gear Lever (Main Gearbox).
7. Gear Lever (Auxiliary Gear-box).
8. Four Wheel Drive Lever.
9. Winch Clutch Lever.
10. Engine Speed Control Hand Lever.
12. Ether Starting Device.
13. Ether Starting Butterfly Valve Control.
14. Battery Cut-out Switch.
15. Electrical Control Unit (C.A.V.)
(For Simms' Electrical Control Unit, see Fig. 40).
16. Starter Button.
17. Dynamo Indicator Light.
18. Tail Lamp Switch.
19. Side Lamp Switch.
20. Head Lamp Switch.
21. Starting Switch.
22. Inspection Lamp Connection.
24. Oil Pressure Gauge.
25. Air Pressure Gauge.
26. Speedometer.
27. Instrument Panel Light Switch.
28. Horn Push.
29. Warner Brake Controller.

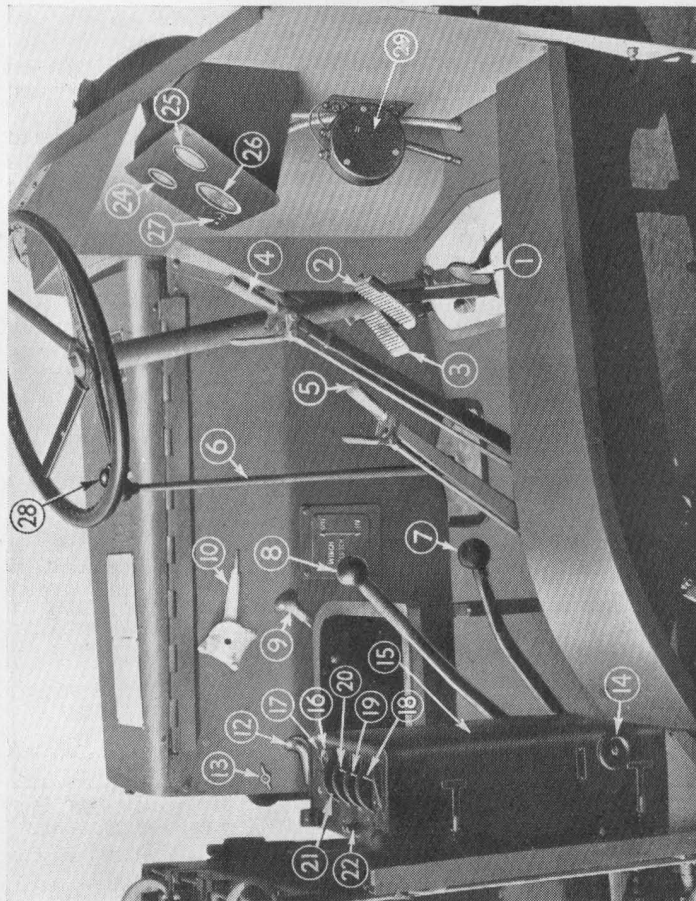

Fig. 2. Driver's Controls.

CONTROLS.

(The index numbers correspond to those in Fig. 2, unless otherwise stated).

FOOT

1. **Accelerator.**

The right-hand pedal operates the fuel injection pump and thus controls the speed of the engine. Depress pedal fully when starting engine. Lift with toe, to stop engine.

2. **Brake.**

The centre pedal operates the brakes on all four wheels.

3. **Clutch.**

The left-hand pedal operates the clutch. Do not rest foot on this pedal when driving and do not hold clutch out to coast.

HAND.

4. **Brake.**

This is the longer of the two levers on the driver's right, and operates the brakes on rear wheels only. To apply brake, pull lever back ; to release brake, grip the trigger lever and return hand lever to forward position.

5. **Winch Brake.**

Just behind the hand brake lever, the shorter of the two. It should always be in the " on " position (back) except when winching.

6. **Gear Lever (Main Gearbox).**

The long lever on left of driver and opposite the hand brake lever. It is used for changing the gears in the main gearbox to obtain different speeds. To engage reverse gear, **lift knob** at top of lever and push over to your left side as far as it will go, then pull towards the rear. The movements of the gear lever to obtain the various gears are indicated on a plate on top of the bonnet.

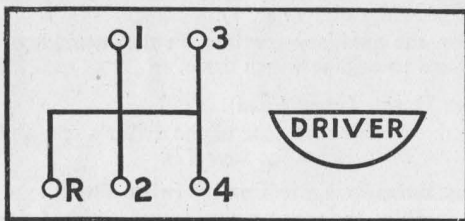

Fig. 3. Gear Positions (Main Gear Lever).

7. Gear Lever (Auxiliary Gearbox).

The **outside** ball handle lever at right of the driver. It is used for changing the auxiliary gear to high or low. **High gear is always used for normal road work** ; low or high gear may be used with four wheel drive. Low gear cannot be engaged unless front wheel drive is also used.

Movement of lever is :—

Up for low gear.

Central for neutral (position for winching).

Down for high gear.

8. Four Wheel Drive Lever.

The **inside** ball handle lever at right of the driver is for engaging four wheel drive or rear wheel drive only.

Rear wheel drive is always used for normal road work.

Movement of lever is :—

Up for four wheel drive.

Down for rear wheel drive.

9. Winch Clutch Lever.

This is on the driver's left at the rear.

Movement of lever is :—

Up for clutch out.

Down for clutch in.

Except during winching, this lever must be in the " up " position in the clip provided.

10. Engine Speed Control Hand Lever.

The small lever mounted on the side of the bonnet to the left of the driver. It is used to regulate the speed of the engine, as during winching, without the necessity for keeping foot on the the accelerator pedal. **It must be in the shut position (down) before the engine can be stopped, by lifting the accelerator pedal.**

11. Winch Engagement Lever (Fig. 1).

Mounted on the auxiliary gearbox on the nearside of the vehicle. Move forward to engage winch drive.

12. Ether Starting Device (when fitted).

This is mounted on the left side of the driver's seat and is operated by a lever (*for instructions see page 12*).

13. Ether Starting Butterfly Valve Control (when fitted).

The small knob at the rear on the driver's side of the bonnet (*for instructions see page 12*).

14. Battery Cut-out Switch (C.A.V.)

Knob on outer face of the electrical control unit. It must be pressed "in" before starting the engine; when it is "out" the battery is isolated from all electrical wiring beyond the feeds to the Electrical Control Unit. (For illustration of Simms' Electrical Control Unit, see Fig. 40).

15. Electrical Control Unit. (*Units of C.A.V. and Simms' manufacture are fitted, the controls of which are dissimilar. A C.A.V. unit is shown in Fig. 2, while Fig. 40 on page 58, shows a Simms' unit.*)

On right-hand side of driver. In the panel on top of this unit are the following:—

16. Starter Button.

Push in to start the engine; after closing (14) and (21).

17. Dynamo Indicator Light.

This should only glow red when the battery cut-out switch (14) and the starting switch (21) are "closed" and the engine is stationary or idling. If the light appears when the engine is running fairly fast, the dynamo is not working and it must be reported at once.

18. Tail Lamp Switch. This also controls the axle flood lamp.

19. Side Lamp Switch.

20. Head Lamp Switch.

The movements for operating these switches are indicated on the panel.

21. Starting Switch.

This must be switched "on" before the starter button will operate; it must be left in this position while the engine is running. When the vehicle is not in use, it must be switched "off" and the engine stopped by lifting the accelerator pedal.

22. Inspection Lamp Connection.

Two sockets to take the 2-pin plug attached to the inspection lamp supplied. The battery cut-out switch (14) must be "in" to use this lamp.

23. Rear Axle Flood Lamp Switch (*Fig. 4*).

This is mounted on the rear cross-member.

To change over from tail lamp to axle flood lamp,

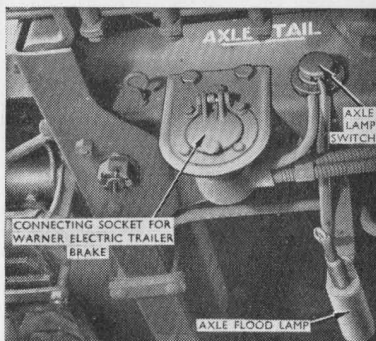

Fig. 4. Rear Axle Flood Lamp Switch.

move the lever to the left ; to cut out the axle lamp and operate the tail lamp, move lever to the right.

The switch marked "tail" (18) on the electrical control unit must be "on" for either the axle lamp or tail lamp to operate.

INSTRUMENTS.

On the instrument panel just in front of the steering wheel are mounted the following instruments :—

24. Oil Pressure Gauge.

This registers lubricating oil **pressure**, not the quantity of oil in the engine. It should read 60 lb./sq. inch when the engine is running at the maximum governed speed of 1,800 R.P.M.

25. Air Pressure Gauge.

This indicates the amount of air pressure available for braking. It should normally read between 80 and 90 lb./sq. inch (Westinghouse) or 95 and 100 lb./sq. inch (Clayton-Dewandre) (*See page 19*).

26. Speedometer.

This registers the speed of the vehicle and total mileage.

Note.—Early vehicles had additional gauges showing the Radiator water and Engine oil temperatures.

27. Instrument Panel Light Switch.

28. Horn Push.

This is mounted on top of the bonnet.

29. Warner Brake Controller.

Although illustrated in Fig. 2, this controller is only fitted to the front dash on vehicles having air pressure braking. On other vehicles it is mounted in the chassis frame adjacent to the Servo Motor (*see Fig. 31*).

30. Fuel Cock (Fig. 5).

Mounted on top of the fuel tank on offside of chassis. It has three positions, "main," "off" and "reserve."

Keep at "main" position; use "reserve" only in an emergency and return to "main" as soon as tank is filled again.

Do not turn to "off" position except when dismantling fuel piping.

31. Tyre Inflator (Figs. 7 and 8).

This is on nearside of chassis frame just behind the air storage tank. A flexible tube connection is supplied, also a key for turning on air. The key can only be removed when the cock is in the "off" position.

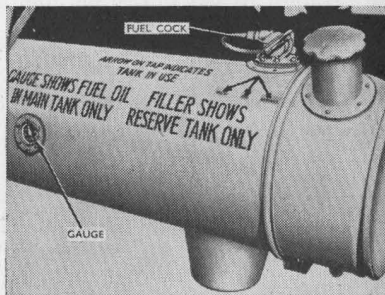

Fig. 5. Fuel Cock on Fuel Tank.

ENGINE STARTING AND DRIVING

INSTRUCTIONS.

A. Before Starting the Engine, see that :

- (i) Radiator is full of water, or, if anti-freeze solution is in use, it is within 1 in. below the level of the top rim of the gauze strainer.
- (ii) Oil in the engine sump is up to the top mark of the dipstick.
- (iii) Fuel tank is full and cock is in " main " position.
- (iv) Main change speed lever is in neutral position.

The oil level in the sump should be maintained as near to the full mark as possible as this results in lower oil temperatures and higher lubricating qualities.

B. To Start the Engine (Temperatures above 16 deg. F.).

- (i) Close the battery cut-out switch (14), *Fig. 2.*
- (ii) Move the starting switch (21) to the " on " position.
- (iii) Depress the accelerator pedal **fully**.
- (iv) Press the starter button (16) firmly.
- (v) Release starter button as soon as the engine starts.

If the engine does not pick up in a few seconds, do not keep the starter running as to do so will exhaust the battery ; **wait for the engine to come to rest**, then begin again. It will sometimes be found necessary to keep the accelerator pedal more or less fully depressed for a few moments after the engine starts, but as soon as it has warmed up slightly this will not be necessary.

- (vi) Immediately the engine starts, check the reading of the oil pressure gauge ; it should be approximately 60 lb./sq. inch. It will be higher if temperature is low, but may reduce to 25 lb./sq. inch (idling) as the oil warms up.

If the engine fails to start, vent the fuel system (*see page 34*).

C. To Start the Engine (Temperatures near or below 16 deg. F.).

When temperatures are sufficiently low to call for the use of the Ether starting device, the felt element in the main fuel filter must be exchanged for the brass wire gauze type (carried on vehicles equipped with Ether starting device) (*see page 34*), then proceed as follows :—

- (i) Press in the battery cut-out switch (14) (Fig. 2).
- (ii) Move the starting switch (21) to the "on" position.
- (iii) Remove the dummy capsule from the "Ethalet" tool (see Fig. 6).
- (iv) Lift the lever of the puncturing tool and insert "Ethalet" capsule neck in the recess provided on the spring platform. Discharge Ether contents of capsule by pressing down the lever with a quick movement to its lowest position.
- (v) Close starting butterfly valve by pulling knob (13), Fig. 2.
- (vi) Depress accelerator pedal **fully**, and press starter button firmly.
- (vii) After the engine has fired and been firing for 10-30 seconds, gradually open starting butterfly valve by pushing in knob (13), Fig. 2. If there is a tendency for the engine to stop, immediately reclose butterfly.
- (viii) Continue (vii) until the engine is running with starting butterfly fully open, *i.e.*, knob pressed in.

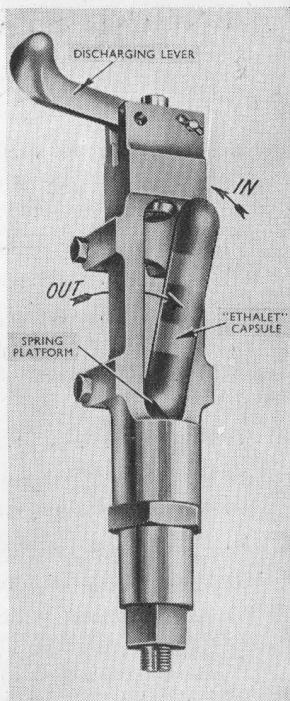

Fig. 6. "Ethalet" Tool.

- (ix) Gradually allow accelerator pedal to rise until engine idles satisfactorily.
- (x) Remove the used "Ethalet" capsule, by lifting the lever to upper position and removing capsule with fingers at slotted opening.
- (xi) Replace dummy capsule.
- (xii) If engine fails to start, insert a second "Ethalet" capsule and repeat the above procedure.

The felt element must be fitted in place of the gauze type in the main fuel oil filter when warmer conditions exist.

Do not race the engine to warm up, but let it run slowly at about quarter throttle for a few minutes before driving off.

When starting from cold in frosty weather, see that the blanking flap is in position on the lower portion of the radiator front grill. As this flap will permit the vehicle to operate satisfactorily under atmospheric temperatures up to 90° F., it should only be removed if the vehicle is to operate in tropical climates.

D. To Stop the Engine.

Lift the accelerator pedal with the toe, and hold in raised position until the engine stops.

GENERAL HINTS ON DRIVING.

- (i) For normal road conditions use high auxiliary gear and rear wheel drive, *i.e.*, both auxiliary gear levers (7) and (8), *Fig. 2*, in the "down" position.
- (ii) Start in 2nd "main" gear unless on an up gradient.
- (iii) Do not rest your foot on the clutch pedal when driving and do not hold the clutch out to coast.
- (iv) Use "top" gear as much as possible and do not change down while the engine has the load well in hand. When climbing hills, do not wait, however, until the engine is labouring before changing down.
- (v) Do not race the engine unnecessarily, and when going up a hill in low gear, change up as soon as the speed will allow.
- (vi) The engine is governed to a speed of 1,800 r.p.m. under load which limits the speed of the vehicle as follows:—

Gear.	ROAD SPEED IN M.P.H.		
	7.9 : 1 Axle Ratio with High Auxiliary Gear.	6.25 : 1 Axle Ratio with High Auxiliary Gear.	For both Ratios with Low Auxiliary Gear.
1st	7	8	3
2nd	11	14	5
3rd	19	24	8
4th (Top)	30	38	13

Note.—Axle ratios are stamped as shown in Figures 28 and 29.

To Move Off.

Where road conditions are normal, engage high auxiliary gear and rear wheel drive, by pushing down both auxiliary gear levers then, after running the engine at about quarter speed for a few moments, proceed as follows:—

- (i) Depress and hold down the clutch pedal.
- (ii) Place "main" gear lever in 2nd gear position, *i.e.*, press sideways away from you, then pull towards the rear.
- (iii) Release hand brake.
- (iv) Allow clutch pedal to come up slowly and at the same time press down accelerator pedal.
- (v) When the vehicle has reached about the speed shown in the table below, press down the clutch pedal and at the same time release the accelerator pedal.
- (vi) Move "main" gear lever to the 3rd gear position, *i.e.*, push forward half-way, then pull sideways towards you as far as it will go and then move forward.
- (vii) Release clutch pedal slowly, and at the same time press down the accelerator pedal as before.
- (viii) When the vehicle has reached the speed shown in the following table, for this gear, repeat the process and pull main gear lever into 4th gear position (top).

Changing UP with 7.9 : 1 Axle and 2.31 : 1 Auxiliary Gearbox ratios :

From	To	High Auxiliary Gear.		Low Auxiliary Gear.	
		On Level.	Uphill.	On Level.	Uphill.
1st Gear	2nd Gear	—	7	—	3
2nd „	3rd „	8	11	3½	5
3rd „	4th „	14	18	6	8

With 6.25 : 1 Axle and 2.91 : 1 Auxiliary Gearbox ratios :

1st Gear	2nd Gear	—	8	—	3
2nd „	3rd „	11	14	3½	5
3rd „	4th „	19	24	6	8

Changing Gear on Hills.

When moving from rest up hill, instead of starting with the main gear lever in 2nd gear, engage 1st gear and change to the 2nd gear when the speed is approximately as given in the above table against the appropriate gear ratio fitted to the vehicle and whether in high or low auxiliary gear. Carry on with the other gear changes as set out above referring to the appropriate portion of the table.

When the vehicle is climbing a hill in 4th (top) gear and its speed drops, it is necessary to change down into 3rd gear. To do this, double de-clutch as follows :—

- (i) Release the accelerator pedal.
- (ii) Press down the clutch pedal and at the same time move the gear lever into neutral.
- (iii) Release the clutch pedal, at the same time pressing down the accelerator pedal for a moment and then releasing it. (This is to bring the engine speed up to the same as the vehicle speed for the gear about to be engaged.)
- (iv) Press down the clutch pedal and move the gear lever into the lower gear position.
- (v) Release clutch pedal smoothly and press down accelerator pedal.

The following table gives a guide to the speeds at which the gear should be changed DOWN when the vehicle is travelling up hill :—

From	To	7.9 : 1 with High Auxiliary Gear.	6.25 : 1 with High Auxiliary Gear.	For both Ratios with Low Auxiliary Gear.
4th (Top)	3rd	20	26	9
3rd	2nd	12	15	6
2nd	1st	7	8	4

You must stop the vehicle to change auxiliary gear or to engage four wheel drive or rear wheel drive.

To Stop the Vehicle.

- (i) Release the accelerator pedal and depress brake pedal.
- (ii) When the vehicle has slowed down to a speed of approximately 10 m.p.h., press down the clutch pedal and move the main gear lever into neutral. Then release the clutch pedal.
- (iii) When the vehicle is stopped, pull on the hand brake and release brake pedal.

Before leaving the Vehicle at night :—

- (i) Apply hand brake.
- (ii) Place main gear lever in "neutral" position.
- (iii) Stop the engine by lifting the accelerator pedal.
- (iv) Switch off lights and the switch marked "start" on electrical control unit.
- (v) Pull out the battery cut-out switch.

- (vi) In cold weather, see that frost precautions are observed (*see below*).
- (vii) Open both drain cocks on air storage tank (*Figs. 7 and 8*), until clear of all air and moisture, then close and remove handles. The handles can only be removed when the cocks are closed.

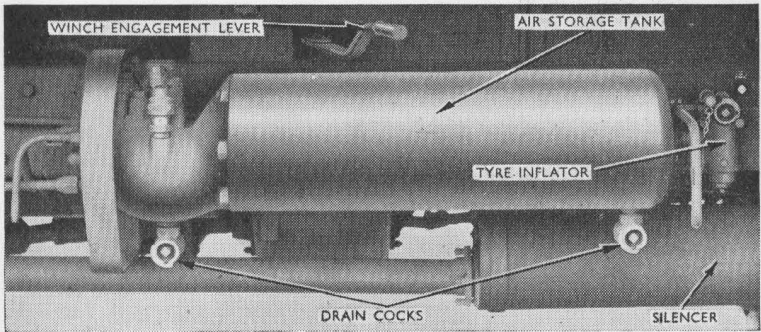

Fig. 7. Air Storage Tank (Westinghouse).

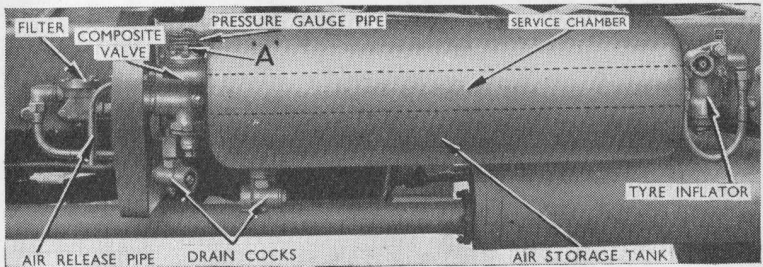

Fig. 8. Air Storage Tank (Clayton-Dewandre).

FROST PRECAUTIONS.

(A) PROTECTION BY USE OF ANTI-FREEZE MIXTURE.

Vehicles with anti-freeze mixture in the engine cooling system have an identification mark in the form of a disc painted in a specified colour on the front of the vehicle.

If your vehicle is so marked, your instructions are as follows :—

- (i) **Do not drain the cooling system unless instructed to do so.**
- (ii) **If the cooling system has to be emptied, see that you have the right number of containers at hand before draining, and collect the mixture for re-use (approximately 6 gallons).**
- (iii) **Top up the radiator with anti-freeze solution (NOT WATER) when the engine is hot.**
- (iv) **Top up to 1 in. below the top rim of the strainer. Do not over-fill.**
- (v) **If for any reason the mixture is lost and the system is filled with water, paint out the coloured disc.**

Brake Anti-freezer : To prevent the valves of the air compressor and various other units in the air pressure system, from freezing in severe weather, the anti-freezer fitted to the nearside chassis frame must be filled with "I.M.S. substitute" or "Methanol" when frost precautions are ordered, and the operating cap must be pulled up (*see Fig. 38*).

(B) PROTECTION BY DRAINING THE ENGINE COOLING SYSTEM (where anti-freeze is not used).

If anti-freeze solution is not available and the vehicle is to remain standing in the open with temperatures approaching freezing point, the cooling system must be completely drained as follows :

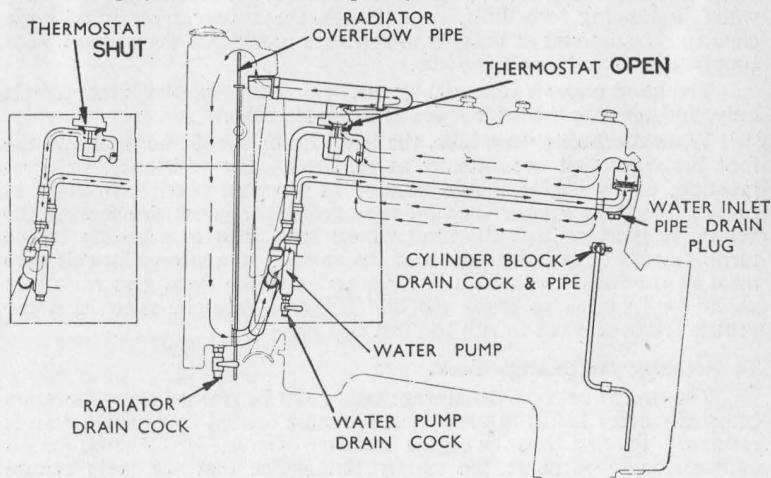

Fig. 9. Diagram of Water Cooling System

- (i) Drain points are positioned as follows :—
- (a) Radiator bottom tank (drain cock).
 - (b) Water pump body (drain cock).
 - (c) Nearside rear of cylinder block (drain cock).
 - (d) Water inlet pipe at rear of cylinder block (drain plug).

Fig. 9 shows the positions of these four drain points, all of which must be opened to drain the system completely.

- (ii) Drain cocks must be tested at frequent intervals by inserting a piece of wire to ensure that they are clear. This should be done immediately they are opened so that any obstruction freed by the wire may be flushed out by the water.
- (iii) Drain when the engine is hot and do not leave the vehicle until the water is properly drained from all points. Close the cocks and replace the plug when drained.
- (iv) After draining, place a notice on the radiator to the effect that it is empty.

BRAKES.

Four wheel brakes are provided for the foot brake, using the Lockheed hydraulic system, assisted by an air pressure servo. The air supply for the foot brake is obtained by a compressor driven off the main gearbox ; **it is important, therefore, that the vehicle is not coasted** in “ neutral ” when descending long hills, as although the supply tank is of large capacity, the amount of braking under these conditions would reduce the supply, the compressor being idle.

The hand brake is operated by mechanical linkage on the rear wheels only, and actuates the same shoes as the foot brake.

When descending long hills, the hand brake should be used and the foot brake applied occasionally as required. The resistance, or compression, of the engine should be used as much as possible to assist in braking, by taking your foot off the accelerator pedal **and leaving the vehicle in gear**, so that the road wheels have then to keep the engine turning against the compression of the engine. On steep hills this help must be increased by using a lower gear, using the same gear ratio that would be required to climb the hill, but care must be taken that the vehicle is not allowed to run too fast (*see page 13*).

To Recharge the Storage Tank.

The drain cocks on the storage tank must be opened every 24 hours (normally every night) in order that moisture caused by condensation is released ; the first time the engine is started afterwards will cause the air compressor to recharge the supply tank. **See that the main change speed lever is in “ neutral ” and run the engine at about quarter throttle (do not touch clutch pedal).**

During charging with the Westinghouse system, the air pressure gauge will rise to 65 lb./sq. inch and will remain at this figure for about 2 minutes until both compartments of the supply tank reach the same pressure. The gauge will then rise to approximately 90 lb./sq. inch when a valve will operate with a hiss, indicating that the system is charged; the compressor will then automatically run light.

With the Clayton Dewandre system no pause takes place on the gauge at 65 lb./sq. inch, but there will be a pause between the moment at which the engine starts and when the gauge commences to register, after which the gauge will rise steadily until approximately 100 lb./sq. inch is reached.

Get used to the feel of the brakes as soon as possible.

The air pressure gauge must show at least 75 lb./sq. inch before driving the vehicle.

Before getting out of your seat to leave the vehicle, always apply the hand brake.

USE OF WINCH.

The winch may be used for unditching the vehicle to which it is fitted by attaching the winch cable to a suitable anchorage in line with the tractor either to the front or the rear.

It may also be used for unditching a second vehicle, in which case the skid pans provided must be placed under the front wheels of the unditched vehicle, as shown in *Fig. 10*, to ensure sufficient hold.

To Pay out the Cable.

- (i) See that the winch engagement lever, which is mounted on the auxiliary gearbox at the nearside of the chassis, is back in the "out" position.
- (ii) See that the winch brake is "off."
- (iii) See that the winch clutch lever is in the "up" position in its clip.
- (iv) The winch drum is now free and the cable may be pulled out by hand. **Never pay out by driving the winch in reverse.**

After the cable has been payed out and is lying on the ground, **never allow another vehicle to pass over it as this will cause kinks in the cable which interfere with the proper winding on the drum.**

To Pull in the Cable.

- (i) Place the main gear lever in "neutral" and the outside auxiliary gear lever in the "winch" position.
- (ii) Move the winch engagement lever, which is mounted on the auxiliary gearbox at the nearside of the chassis, in a forward direction to engage the winch drive.

- (iii) Move the winch clutch lever (*Fig. 2*) downwards to operate the dog clutch engaging the winch drum with the driving gear.
- (iv) Start the engine.
- (v) See that the winch brake is "off."

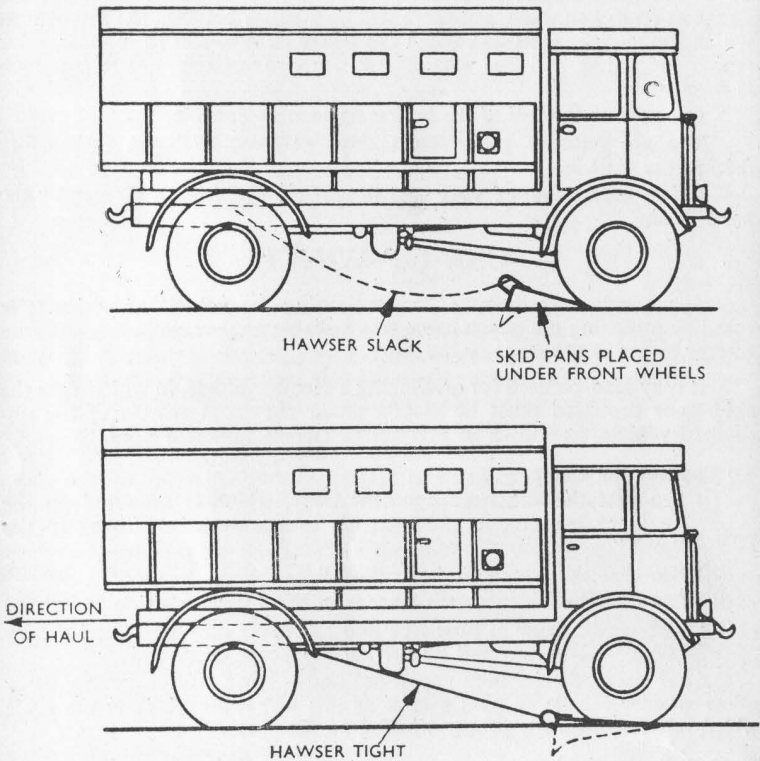

THE SKID PAN HAWSERS MUST BE ADJUSTED SO THAT THEY ARE TIGHT WHEN THE FRONT WHEELS ARE AT THE TOP OF THE SKID PANS. ON HARD GROUND THE FLAT SURFACES OF THE SKID PANS MUST BE TO THE GROUND SO THAT THE WHEEL RESTS IN THE PAN. ON SOFT GROUND THE POSITION OF THE SKID PANS MUST BE AS ILLUSTRATED.

Fig. 10. Method of Anchoring Vehicle for Winching.

- (vi) Depress the clutch pedal, engage first gear in main gearbox and take up load on cable gently, by releasing clutch pedal and pressing down accelerator pedal. Exercise care when operating the winch to avoid snatching, full use being made of the engine clutch and the accelerator pedal, or engine speed hand lever in a progressive manner.

NEVER PULL IN A SLACK CABLE.

THE WINCH MUST NOT BE DRIVEN IN ANY GEAR HIGHER THAN 2ND.

To hold the load, press down clutch pedal, release the accelerator pedal (or engine speed hand lever) and pull up on winch brake lever. If it is required to hold the load for any length of time, disengage the winch clutch.

To Winch the Tractor Forward.

- (i) Pay the cable round the pulley on the nearside rear corner of the frame, making sure that it is fitted into the pulley groove and inside the retaining plate.
- (ii) Carry the cable forward along the frame and over the top of the protecting bar at the front of the air storage tank.
- (iii) Remove outer guide roller from its support at the front of the frame, by withdrawing the pin. Place cable against inner roller, then replace outer roller and pin.
- (iv) Attach end of cable to holdfast in line with the tractor. The front guide roller is not designed to carry an excessive side load.

Note.—Winching from the front should not be used for unditching another vehicle.

When Winding Operations are Completed.

When winding operations are completed, wind up the cable, keeping it taut while doing so. **Never haul in a slack cable.** When the cable is fully wound (do not over-wind), press down clutch pedal, release accelerator pedal (or engine speed hand lever) and apply the winch brake. Pull up the winch clutch lever and move the winch engagement lever towards the rear.

BE SURE THE WINCH IS DISENGAGED BEFORE MOVING THE VEHICLE.

Note.—A safety device is fitted which stops the engine when the pull on the cable reaches danger point. If this happens, apply the winch hand brake immediately and skotch the load.

PERIODICAL ATTENTION.

(Items NOT covered by the Tasks).

The following items require regular attention in addition to the maintenance routine covered by the Tasks. When climatic and working conditions are exceptional it must be left to the discretion of the authority on the spot to vary periods at which this attention is given, so that actual conditions are suited.

It should be noted that for engine, fuel injection pump, air cleaners and air compressor filling, summer and winter grades of oil are provided.

Basing normal attention on the following periods, check all items indicated and if necessary, report defects.

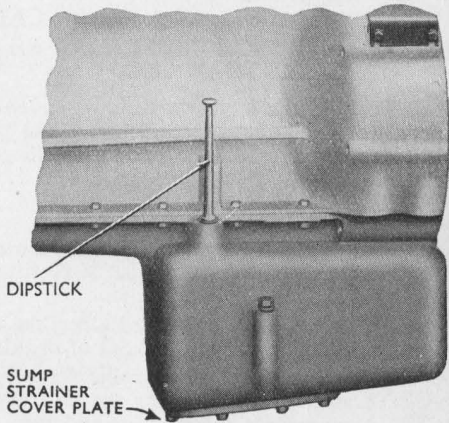

Fig. 11. Engine Oil Dipstick.

DAILY.

- | | | |
|-------------------------------|-------|--|
| Engine Sump | | Check level of oil in sump and top up if necessary, with 30 H.D. to top mark on dipstick (Fig. 11). Do not fill above the level indicated. |
| Fuel Injection Pump | .. | (a) Remove dipstick and check if oil level is up to top mark on dipstick (<i>Lubrication Chart Reference No. 25</i>).
(b) If necessary, unscrew oil filler on Simms pump and add sufficient oil 30 H.D. to bring oil level up to mark on dipstick. On C.A.V. pump, replenish with oil 30 H.D. through the dipstick hole.
(c) Replace dipstick and oil filler plug. |
| Fuel Injection Pump Governor. | | (a) Unscrew oil level plug on governor (Figs. 41 and 42). If oil runs out this indicates that there is sufficient oil in the governor casing. If no oil runs out, unscrew governor oil filler plug on Simms pump, or oil cap on C.A.V. |

pump, and pour in oil 30 H.D. until it runs out of the level plug (*Lubrication Chart Reference No. 25*).

(b) Replace level plug and filler plug and tighten.

- | | | | |
|------------------------------------|----|----|--|
| Radiator | .. | .. | Check level of water in radiator and top up if necessary, with water (rain water if obtainable) or anti-freeze solution as ordered (<i>see frost precautions on page 16</i>). |
| Fuel Tank | .. | .. | Check quantity of fuel in the fuel tank and fill up. See that fuel cock is at "main" position. |
| Tyres | .. | .. | Check with the gauge provided and, if necessary, inflate to correct pressures as instructed. |
| Brake Air Storage Tank | | | Open both drain cocks to allow all moisture to escape, then close and remove handles from cocks; the handles can only be removed when the cocks are closed. (Normally to be done every night, <i>see page 18</i>). |
| Brake Air Pressure | .. | .. | Start the engine and note reading on gauge; with the accelerator pedal depressed a quarter of its travel, the gauge should reach at least 80 or 95 lb./sq. inch according to type of air pressure equipment (<i>see page 10</i>) after approximately three minutes running from zero reading. Depress and release brake pedal and listen for hiss of air. If this occurs, the air pressure is functioning. |
| Lighting and Black-out Regulations | .. | .. | Close the battery cut-out switch and check the lights for operation and compliance with black-out regulations. Switch "off" again after this test. |
| Miscellaneous | .. | .. | Look for any new stains on the ground under the vehicle, indicating leaks, and report if necessary.
Check security of removable fittings, locker doors, etc. |

Faulty Injection . . . Warm up engine and listen for pronounced knock in affected cylinder(s) (*see page 57*), also watch for dirty exhaust. Report defects.

Draining of units must always be carried out when the oil is warm, i.e. after a long run. Clean plugs and caps and surrounding surfaces before removal. Clean oil containers and funnels before use. Dirt allowed to enter casings will cause excessive wear of bearing surfaces.

NEW AND RECONDITIONED UNITS.

In the case of new vehicles, or overhauled engines, change engine oil after the first 250 miles, and again after a further 1,000 miles. The engine sump strainer must also be serviced as described under the heading of "Every 3,000 miles".

The cylinder head holding down nuts should be tightened by workshops and the valve clearances adjusted.

Change oil in main and auxiliary gearboxes, front and rear axles, after the first 2,000 miles, as described under the heading of "Every 5,000 miles".

EVERY 500 MILES.

Clutch Withdrawal Race.—Lubricate with Oil C.600, using gun. (*Lubrication Chart reference No. 6*).

EVERY 1,000 MILES.

Main Fuel Filter (*Fig. 20*). Unscrew the centre nut in the top cover, remove the bowl and extract the element. Swill the element and felt washer in clean fuel oil; remove bottom plug from bowl and wash bowl in clean fuel oil until sludge is removed. When assembling, guard against dirt entering the filter (particularly the inside of the element) and wash your hands before commencing. If the filter becomes inefficient, immediately change the element for a new one.

After cleaning filter, always fill with fuel oil, then vent the fuel system (*see page 34*).

Workshop attention is also required at this mileage interval.

Oil Bath Air Cleaner. Remove by unscrewing the clip at the base. Unscrew the centre nut in the top cover and lift out the filter element. Empty the oil from the base and wash out any sediment. Replace air cleaner body on its mounting and tighten the bottom clip. Fill with new engine oil to level mark just above the shelf. Check that the joint washer in the cover is in good condition and in place. Refit the element and top cover. Tighten securely.

Standing orders will be issued for servicing the cleaner at more frequent intervals under conditions of dust-laden atmosphere.

EVERY 2,000 MILES.

Starter Motor. Lubricate sparingly through the oil cap provided. (*Lubrication Chart reference No. 34*).

Brake Air Strainer (*Fig. 34*). Remove top cover, and clean felt or hair element in petrol.

EVERY 3,000 MILES.

Engine Sump and Strainer. Drain by removing the two drain plugs. Under supervision, remove the sump strainer and cover plate (*see Fig 11*), by unscrewing the six nuts securing the cover plate to the rear end of the bottom of the sump. The sump strainer will be removed with the cover plate—do not separate. Clean the strainer with paraffin, then refit to sump, exercising care that the oil suction pipe enters the hole in the strainer. Refit the two drain plugs and secure with locking wire. Refill with oil to top mark on dipstick.

Brake Air Compressor. Drain by removing drain plug and refill to the level of the top mark on the dipstick. (*See Fig. 37*).

Trailer Brake Air Cylinder. Drain by removing the two drain plugs, one at each end ; and refill to the level of the combined filler and level plug.

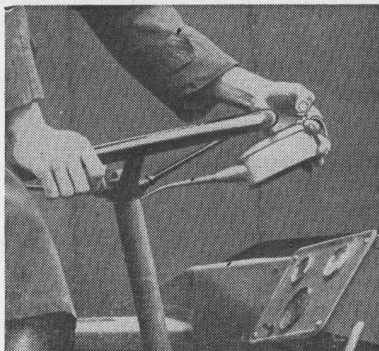

Fig. 12.
Lubrication of
Steering Wheel
Felt Packing.

NOTES

Steering Wheel Felt Packing. Lubricate with oil can. (See Fig. 12). Workshop attention is also required at this mileage interval.

EVERY 5,000 MILES.

Front Axle. Drain and refill. Drain plug is on the near side of the reduction gear casing. The correct oil level is obtained by filling to the level of the plug provided in the front of the casing. (See Fig. 28).

Rear Axle. Drain and refill. Drain plug is on the near side of the reduction gear casing (bevel axles or worm axles). Fill to the level of the plug provided on the rear of the casing. (Fig. 29 illustrates the bevel axle).

Main Gearbox. Drain and refill. Filler plug is accessible through body floor front trap. Fill up to level plug in air compressor drive casing or, on early vehicles, to top mark on dipstick provided in the tool box.

Auxiliary Gearbox. Drain and refill. Drain plugs are not fitted to early vehicles. Drainage, however, may be effected by means of a syringe inserted through the oil filler at offside of box. On later vehicles the drain plug is fitted at the rear of the box. Fill to level plug in filler neck or, on early vehicles, to top mark on dipstick provided in the tool kit.

Servo Motor. (Clayton Dewandre only). Drain and refill. Filler plug on nearside of casing. (See Fig. 31). Top up to level of the filler plug.

Winch Worm Casing. If the winch is frequently and regularly used, drain and refill every 5,000 miles. Access to filler plug on top of casing is through body floor trap. Fill up to level plug on nearside of casing.

ROUTINE MAINTENANCE BY THE DRIVER.

SIXTEEN TASKS.

When carrying out the inspection described in the Tasks, the driver **must not attempt to tighten nuts which are split pinned**. A careful examination must be made for signs of movement or slackness, and if found, must be reported.

Where "Examine and tighten if necessary" appears, it must be understood it is not intended that nuts should be tightened with a spanner every 14 days, but that the joint is to be examined for signs of leakage or movement and tightened only if either condition exists. **ALWAYS STOP THE ENGINE BEFORE MAKING ANY ADJUSTMENT.**

TASK NO. 1

ENGINE.

(A) CLEAN THE ENGINE THOROUGHLY AND INSPECT FOR LEAKS WHEN ENGINE IS RUNNING.

(i) CLAMPING NUTS FOR INJECTORS.

If a leak is detected, stop the engine, then tighten the clamping nuts (Fig. 13), taking care to avoid over-tightening.

(ii) CYLINDER HEAD JOINTS.

Leakage will usually be detected by a deposit of oil and/or water around the joint. If a leak is detected, report at once.

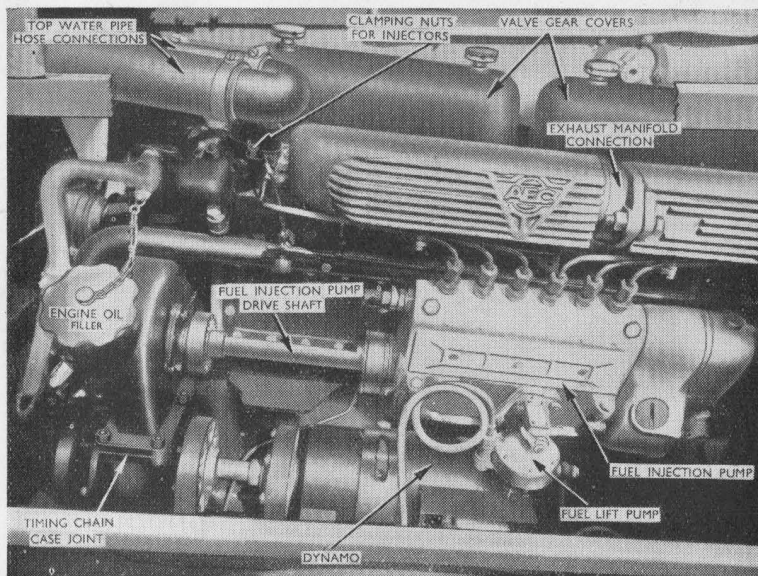

Fig. 13. Nearside View of Engine.

(iii) AIR INTAKE PIPE JOINTS (Fig. 14).

Examine each end of pipe from air cleaner to rear cylinder head, also the rubber connection between the heads. Stop the engine and tighten connections, if necessary.

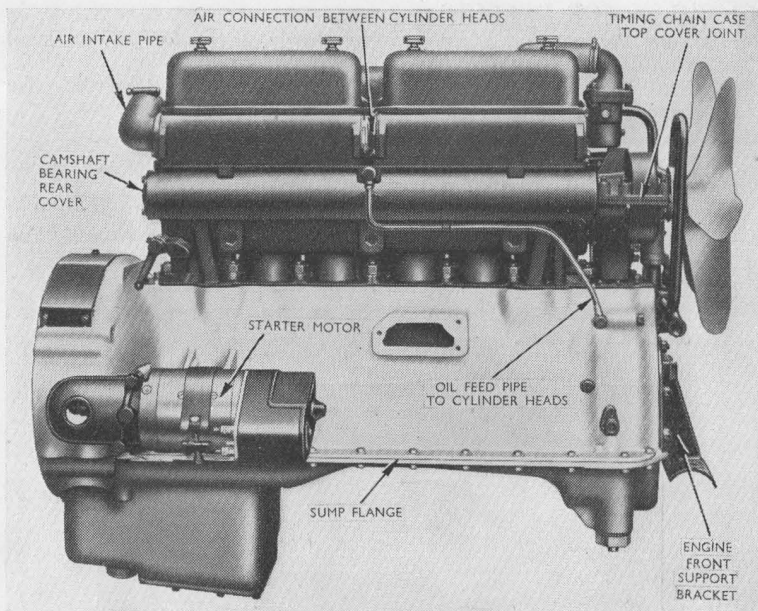

Fig. 14. Offside View of Engine.

(iv) EXHAUST MANIFOLD JOINTS (Fig. 13).

Examine and tighten if necessary, the connection between the two halves of the manifold and the connection to the exhaust pipe.

(B) INSPECT FOR LOOSE NUTS AND BOLTS (and tighten if necessary).

(i) ENGINE MOUNTING.

The two spring loaded bolts under the front crossmember should not be dead tight but should have allowance for movement of the engine against the springs (see Fig. 15).

(ii) The six nuts which hold the front support bracket to the crankcase should also be inspected ; these are split pinned (see Fig. 14).

(iii) The rear of the engine is held by 7 bolts through the bell housing, which also secure the main gearbox to the chassis crossmember.

There are also 2 bolts securing the engine only to the crossmember.

(C) CHECK FOR DEFECTS :

- (i) Start engine, and when running slowly, listen for any unusual sounds.

Knocks are caused in most cases by choked injectors, defective bearings or pistons.

- (ii) Ease of starting.
 (iii) Look for any excessive smoke from the exhaust after the engine is hot.

Black smoke is usually caused by a choked injector, fuel pump out of adjustment or incorrect timing. Blue smoke denotes excessive oil consumption.

- (iv) Examine silencer and exhaust pipe for serviceability.
See that the brackets are tight and that the tail pipe has not become choked with mud.

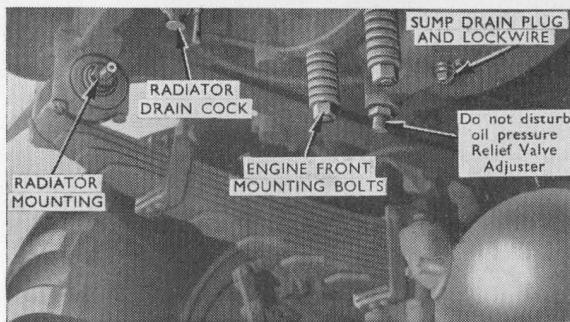

Fig. 15. Engine Front Mounting.

TASK NO. 2

ENGINE LUBRICATION.

- (A) **CHECK LEVEL OF OIL IN SUMP** and refill, if necessary, to the top mark on dipstick (*Lubrication Chart Reference No. 1*). **This is in addition to daily replenishment and periodical oil change ; see page 22. Use oil 30 H.D. (see Figs. 11 and 13).**
- (B) **CHECK READING ON OIL PRESSURE GAUGE** (with engine running).
With engine hot, the pressure should be 25 lb./sq. inch, idling. Do not start up specially for this test but check pressure while driving.

(C) INSPECT FOR LEAKS :—**(i) OIL TIGHT JOINTS.**

If due to loose nuts, tighten gently and report if tightening will not cure.

- (a) Sump strainer cover plate (Fig. 16).
- (b) Sump flange (Fig. 14).
- (c) Cylinder block to crankcase (inspection only).
- (d) Engine front support bracket (Fig. 14) (inspection only).
- (e) Sump drain plugs. **See also that lockwire is secure.** (Figs. 15 and 16).
- (f) Valve gear covers (Fig. 13).
- (g) Timing chain case to crankcase (Fig. 13).
- (h) Timing chain case top cover (Fig. 14).
- (i) Chain tensioner cover in front of crankcase.
- (j) Timing chain skid cover on front of timing chain case.
- (k) Fuel injection pump drive shaft cover on front of timing chain case.
- (l) Fuel injection pump drive shaft cover on rear of timing chain case.
- (m) Camshaft rear bearing cover at rear of cylinder block (Fig. 14).
- (n) Dynamo drive cover.

Do not disturb the oil pressure relief valve adjuster (Fig. 15).

(ii) OIL PIPE UNIONS.

- (a) Oil feed pipe to cylinder heads. **Banjo pin at each end of pipe.** (Fig. 14.)
- (b) Oil pipes to pressure gauge. **Banjo pin on engine, and union connections. Take care not to twist pipe when tightening unions.**

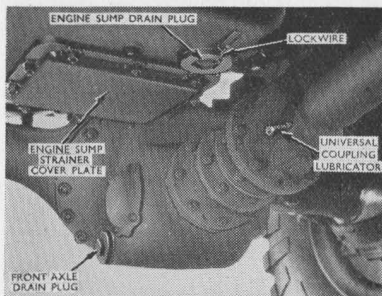

Fig. 16. Engine Sump and Front Axle Casing Joints.

(D) INSPECT EXTERNAL OIL PIPES FOR :—

- (i) Rubbing.
- (ii) Kinks.

If any indication is found, the pipes must be repositioned carefully.

- (iii) Cracks.

Any damaged pipes must be reported.

(E) REPORT DEFECTS.

TASK NO. 3

ENGINE COOLING SYSTEM.

(A) INSPECT :—

- (i) Radiator mounting and tie rod. The radiator is carried on rubber blocks mounted on extensions of the pins through the front dumb irons (*Fig. 15*). The tie rod runs from the rear of the top tank to the rear of the driver's cab.
- (ii) Wire mesh guard on radiator for security and damage.
- (iii) Blanking flap on radiator for security and damage.
- (iv) The bonnet for loose nuts and serviceability of fasteners.

(B) INSPECT FOR LEAKS :—

If due to loose nuts, tighten gently and report if tightening does not cure :—

(i) WATER FLANGED JOINTS :—

- (a) Radiator top tank—water pipe flange.
- (b) Top water pipe—thermostat body (*Fig. 17*).
- (c) Thermostat body—front cylinder head (*Fig. 17*).
- (d) Between front cylinder head and rear cylinder head.
- (e) Rear cylinder head—elbow.
- (f) Elbow—water inlet pipe.
- (g) By-pass pipe connection on thermostat body.
- (h) By-pass pipe connection on water pump body (**report if leaking**).
- (i) Radiator—bottom connecting pipe (**the bolt for this goes through the radiator**).
- (j) Water pump attachment.
- (k) Water pump cover.
- (l) Cylinder side cover (*Fig. 17*).

(ii) RUBBER HOSE CONNECTIONS.

The hose clips should not be tightened unless a leak is found.

- (a) The long top hose (*Fig. 13*).
- (b) The short top hose (*Fig. 13*).
- (c) Water inlet pipe from water pump (*Fig. 17*).
- (d) Radiator to water pump connecting pipe.
- (e) By-pass pipe (*Fig. 17*).

(iii) WATER PUMP.

Look for leakage from the 4 drain holes in the neck of the fixing flange. These 4 holes must be kept clear of obstruction. (Fig. 17).

(iv) DRAIN TAPS AND PLUGS.

One tap on bottom of radiator, one tap on nearside of cylinder block at rear, one tap on bottom of water pump and one plug on water inlet pipe at rear of cylinder block (see Fig. 9).

(C) INSPECT :—

(i) FAN.

See that blades are not bent or broken and check for loose rivets (Fig. 17).

(ii) FAN CLUTCH.

With a fair pull on the tip of the blade, the fan should just slip.

(D) REPORT DEFECTS.

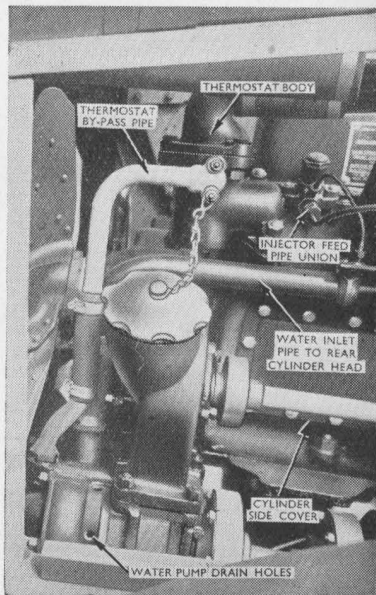

Fig. 17. Part View—Nearside Front of Engine.

TASK NO. 4

FUEL SUPPLY SYSTEM.

(A) INSPECT FOR LEAKS.

Do not slack off any nuts or connections on fuel pipes. Tighten in a right-hand direction.

- (i) Union nuts at each end of fuel pipe, from pump to injectors. Tighten union nuts gently and if tightening does not cure, report. Take care not to twist pipes when tightening 2-piece unions.
- (ii) Union nuts on drain pipes for injectors, and fuel return pipe to tank (see Fig. 19).

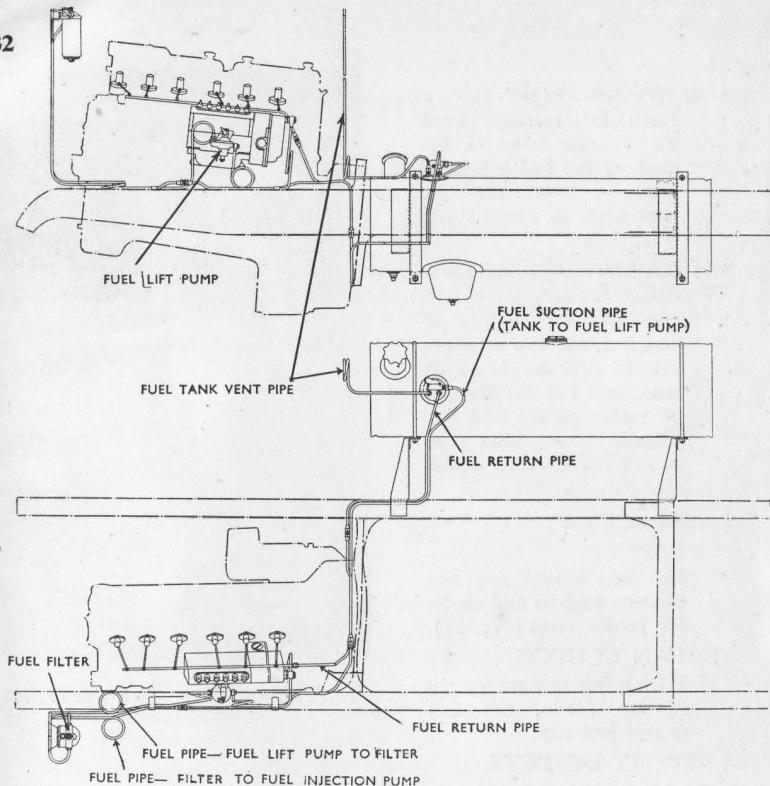

Fig. 18. Arrangement of Fuel System.

(iii) Union nuts on fuel feed pipes (see Fig. 18).

- (a) Tank to fuel lift pump.
- (b) Fuel lift pump to filter.
- (c) Filter to injection pump.

(iv) Joints on fuel lift pump.

Examine the 6 bolts which hold the halves of the pump together, these must be perfectly tight.

(v) Taps, drain and priming plugs for leaks :—

- (a) 2 drain plugs on the fuel tank.
- (b) 1 drain plug under main fuel filter on dash.
- (c) 1 priming plug on top of main fuel filter on dash.
- (d) 3-way fuel tap on top of fuel tank.

(B) EXAMINE FOR DAMAGE :—

- (i) Fuel pipe lines.
- (ii) Fuel tank.
- (iii) Fuel tank air vent pipe.
- (iv) Fuel tank gauge.

(C) INSPECT AND TIGHTEN IF NECESSARY, MOUNTINGS OF:—

- (i) Fuel tank.
- (ii) Fuel filter.
- (iii) Fuel lift pump.
- (iv) Fuel injection pump.

If due to loose nuts, clips, etc., tighten ; if unavailing, report.

(D) LUBRICATION OF FUEL INJECTION PUMP.

Check oil level in :—

(i) INJECTION PUMP.

By dipstick. If replenishment is required, refill with oil 30 H. D. to top mark on dipstick—this is also a daily task (see page 22).

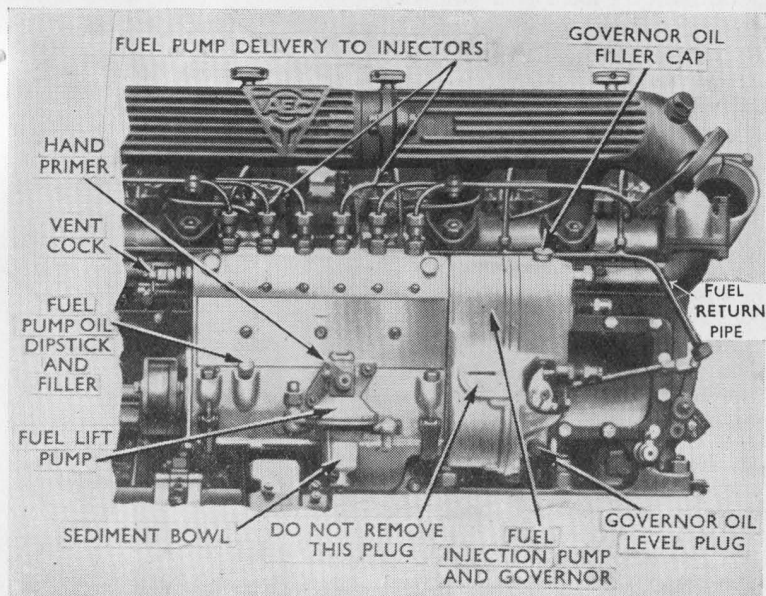

Fig. 19. Fuel Injection Pump (C.A.V.)

(ii) GOVERNOR.

(a) Unscrew oil level plug on governor (*Figs. 41 and 42*). If oil runs out this indicates that there is sufficient oil in the governor casing. If no oil runs out, unscrew governor oil filler plug on Simms pump, or oil cap on C.A.V. pump, and pour in oil 30.H.D. until it runs out of the level plug (*Lubrication Chart Reference No. 25*).

(b) Replace level plug and filler plug and tighten.

(E) EXAMINE FOR FREE FLOW OF FUEL.

(i) Clean out sediment bowl of fuel lift pump (*see Fig. 19*).

Loosen thumb screw on bottom of stirrup and remove bowl; take care not to damage the joint. To remove filter gauze, turn the locking nut in a left-hand direction. Screw up thumb screw tightly after assembling.

(ii) Vent the fuel system (*see (F) below*).

(F) TO VENT THE FUEL SYSTEM, PROCEED AS FOLLOWS :—

It is essential that all air be removed from the fuel system as even air bubbles will interfere with the regularity of the fuel injection. To drive any air from the fuel pump, (a) open vent cock, (b) operate the hand primer on fuel lift pump until fuel flows from vent cock without bubbles, then while still pumping, (c) close the vent cock (*see Figs. 41 and 42*). Should the hand primer not bleed the system, remove plug in top of main filter and fill with fuel oil (*see Fig. 20*).

If the system is free of air, the engine when hot, should accelerate rapidly and without hesitation. If this does not occur, then with engine idling, slack off each injector union (*Fig. 17*) in turn (one at a time), just sufficiently to allow fuel to seep out, and watch for air bubbles between the pipe and the union nut. Should bubbles be detected, leave the nut slack until air free fuel appears. Treat each union in turn in this manner **under supervision**.

NOTE.—If union nuts are slacked off more than just enough to allow the oil

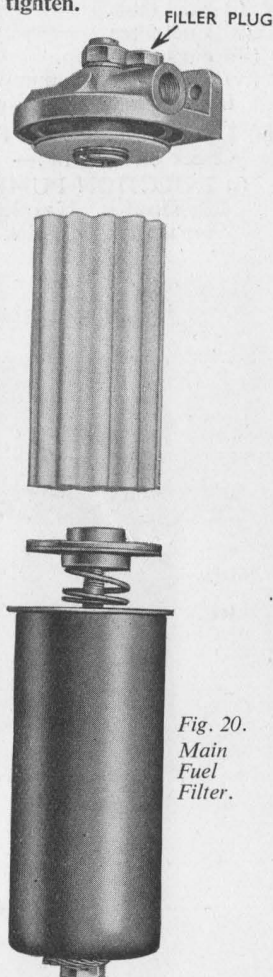

Fig. 20.
Main
Fuel
Filter.

to seep out, the force with which the oil issues from the pipe will produce a froth even if no air is present in the pipe.

After running for a few minutes, open the vent cock for a few moments to make sure that the pump chamber is full of fuel.

(G) REPORT DEFECTS.

TASK NO. 5

ENGINE CONTROLS AND AIR CLEANER.

(A) LUBRICATION.

(i) ACCELERATOR PEDAL SHAFT.

The lubricator is on the offside chassis frame member. Use the gun and oil C.600. (*Lubrication Chart Reference No. 20*).

(ii) ALL FORK ENDS.

There are four fork ends between the accelerator pedal and the injection pump. Clean and oil with can using oil 30 H.D.

(iii) ENGINE CONTROL HAND LEVER.

Clean and apply a little oil 30 H.D.

(iv) OIL BATH TYPE AIR CLEANER.

Fill to "oil level" line with 30 H.D. (*See also page 24*).

(B) TEST FOR CORRECT OPERATION :—

(i) GOVERNOR.

Depress accelerator slowly and verify that the governor is working. As the accelerator pedal is depressed, so the speed of the engine will increase until it reaches the maximum allowed by the governor, and further depression of the pedal will have no effect on the speed. Do not start engine especially for this test, as it can be checked during normal driving.

(ii) ENGINE CONTROL HAND LEVER.

Its operation over full range.

(C) REPORT DEFECTS.

TASK NO. 6

HIGH TENSION LEADS.

This Task does not apply to this vehicle.

TASK NO. 7

MAGNETO OR COIL IGNITION

This Task does not apply to this vehicle.

WINCH.

(TO REPLACE TASKS 6 AND 7).

- (A) **INSPECT FOR LOOSE NUTS AND BOLTS** (and tighten if necessary).

Do not interfere with the locknuts on the winch brake band or on the winch tensioner engine control trip gear (see Figs. 21 and 22).

- (B) **INSPECT CABLE FOR KINKS, FRAYED END AND BROKEN WIRES.**

Kinks in cable, frayed end or damage to the eye or shackle must be reported. The ends of the broken wires must be tucked in.

- (C) **LUBRICATION.**

- (i) **APPLY GUN USING OIL C.600 TO ALL LUBRICATORS.**

The numbers in brackets refer to location of lubricator on lubrication chart, at end of book.

Part	Location	Number of Lubricators
Winch Clutch Shaft ..	(15)	2
Winch Brake Shaft ..	(16)	1
Winch Cable Rollers ..	(17)	4
Winch Cable Guide Pins ..	(18)	5
Winch Worm Gear ..	(35)	1
Winch Bearings	(36)	2

- (ii) **USE OIL CAN WITH OIL 30 H.D. ON THE FOLLOWING PARTS :—**

- Winch brake lever ratchet and fork ends.
- Winch clutch operating fork (Fig. 21).
- Fork ends on winch tensioner engine control trip gear (5 points).

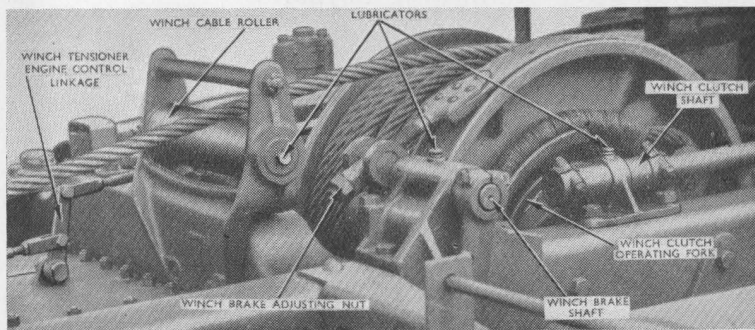

Fig. 21. Winch Details.

- (iii) PAINT THE WINCH CABLE WITH OIL C.600.

To do this, pay out the cable as instructed on page 19. Support and paint the cable with oil C.600 and wind it back on its drum immediately.

For instructions for winding in, see page 19.

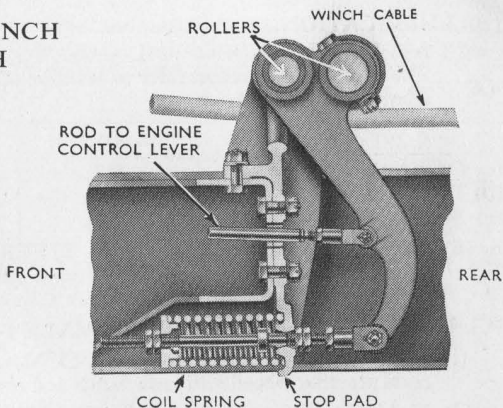

Fig. 22. Winch Tensioner Engine Control Trip Gear.

TASK NO. 8 STEERING.

- (A) INSPECT ASSEMBLY AND TIGHTEN IF NECESSARY.

Do not disturb split pins but report if sign of looseness.

- (i) SECURITY OF STEERING BOX.

3 bolts hold the steering box to the frame ; 1 nut is covered by the end of the engine crossmember, if this is loose, report immediately.

- (ii) EFFECTIVENESS OF STEERING STOPS.

Steering stops must come into contact with axle casing to prevent the grease retainers from fouling the radius in the neck of the swivel ball—one on each swivel, see Fig. 23.

- (iii) TIGHTNESS OF NUTS THROUGHOUT.

2 clamp bolts on drag link, 2 clamp bolts on track rod, nuts on 4 ball pins, nut on drop arm.

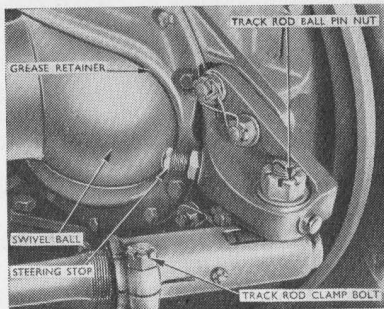

Fig. 23. Front Axle Steering Stop.

(B) LUBRICATION.**(i) APPLY GUN USING OIL C.600 TO LUBRICATORS.**

The numbers in brackets refer to location of lubricator on Lubrication Chart, at end of book.

Item	Location	Number of Lubricators
(a) Drag link	(12)	2
(b) Track rod ends	(13)	2
(c) Steering rocker shaft ..	(37)	1

(ii) CHECK LEVEL OF OIL IN STEERING BOX.

Replenish by plug at base of steering column tube, use oil C.600 up to level of plug hole (*Lubrication Chart Reference No. 31*).

(C) INSPECT FOR WEAR AND DAMAGE :—**(i) END PLAY IN STEERING COLUMN.**

Hold steering wheel with both hands and try to lift it up and down.

(ii) PLAY IN DRAG LINK OR TRACK ROD JOINTS.

A spring loaded ball joint is incorporated at each end of the track rod and the drag link so that no slackness should be felt. To test, turn the steering wheel to the right and left and get someone to check the movement of the linkage. Do not jack up for this test.

(iii) DROP-ARM FOR CRACKS.

Keep metal bright and wipe with an oily rag, examine closely for cracks.

(D) REPORT DEFECTS.**TASK NO. 9****CHARGING SYSTEM (ELECTRICAL).****(A) INSPECT DYNAMO :—****(i) Dynamo mounting straps for tightness.**

Strap bolt securing dynamo to cradle.

(ii) Dynamo coupling bolts for tightness.

7 bolts on each coupling.

(iii) Warning light on top of electrical control unit.

Report if light does not go out when engine is running (to be observed during normal running).

(B) INSPECT BATTERY :—**(i) Examine battery for security in housing.**

Mounted in body under front seats.

(ii) Battery top to be clean and dry.

- (iii) Battery terminals for tightness and freedom from corrosion. **Must be clean and kept freely coated with Lanoline or petroleum jelly (NOT grease) to prevent acid attack.**
- (iv) Battery vent plug holes. **See that these are clear.**
- (v) Battery electrolyte level. **Should be $\frac{1}{4}$ " above plates. Top up with distilled water and dry off any spilt.**

(C) REPORT DEFECTS.

TASK NO. 10

STARTER MOTOR, LIGHTS, ETC.

(A) INSPECT :—

- (i) Starter motor mounting for tightness. **Starter motor is secured by strap and bolt, also by cap bolted on crankcase (see Fig. 14).**
- (ii) Check operation of starter motor. **If starter is unduly noisy in operation or if tendency to jam or failure to engage, report ; no special test is necessary as it should be observed in normal use.**

(B) LIGHTS AND ACCESSORIES.

- (i) Loose mountings. **Lamp bracket bolts and security of lamps on brackets.**
- (ii) Mounting of electrical control unit (Fig. 2).
- (iii) All exposed leads for rubbing and "shorts." **If any indication of "shorts" or rubbing, the leads must be repaired as necessary and repositioned.**
- (iv) Windscreen wipers. **Give just a drop of oil 30 H.D. to the spindle bearings where the wiper spindles protrude from the cab.**

(C) REPORT DEFECTS.

TASK NO. 11

CLUTCH AND GEARBOXES.

(A) CLUTCH.

- (i) Report if oil is found to be dripping from hole at bottom of clutch casing.
- (ii) Check clutch pedal clearance. **Should have 1" upward lift. Adjust by nut on operating rod at base of pedal (see Figs. 24 and 25). Unscrew to increase upward lift.**

(iii) Check clutch brake clearance.

There should be $3/16"$ clearance between the end of the spring plunger and the face of the clutch brake lever, when the latter is pushed forward by hand as far as it will go (see Fig. 25). To adjust, slacken off the 3 point locknut on offside of gearbox and turn adjusting knob, then retighten the locknut.

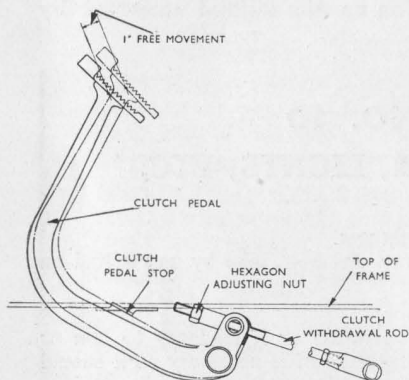

Fig. 24. (Above)—
Clutch Pedal Adjustment.

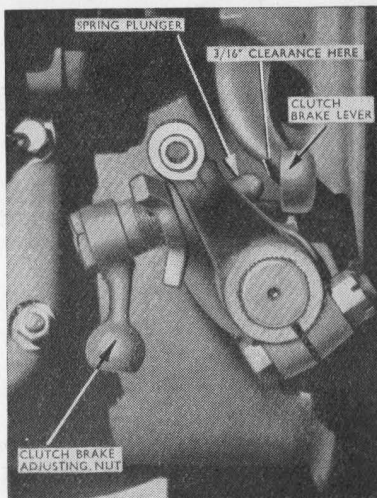

Fig. 25. (Right)—Clutch Brake Adjustment.

(B) GEARBOXES.

Inspect oil tight joints for leaks :—

(i) MAIN GEARBOX :

- | | |
|--|-------------------|
| (a) Mainshaft cover. | } At rear of box. |
| (b) Layshaft cover. | |
| (c) Selector shaft cover. | |
| (d) Selector shaft cover at front of box. | } Offside of box. |
| (e) Joint between selector box and main casing. | |
| (f) Selector box cover. | |
| (g) Joint between compressor and main casing on nearside of box. | |

(ii) AUXILIARY GEARBOX :

- | | |
|-----------------------------------|--------------------|
| (a) Mainshaft cover. | } At front of box. |
| (b) Front axle drive shaft cover. | |
| (c) Speedometer drive. | |
| (d) Winch drive shaft cover. | |

- (e) Output shaft cover.
 - (f) Countershaft cover.
 - (g) Winch drive shaft cover.
 - (h) Bush for operating shafts at offside of box.
 - (i) Bush for winch gear operating shaft at nearside of box.
 - (j) Cover joint.
 - (k) Breather. This should be cleaned at the same time.
- } At rear of box.
} At top of box.

(iii) MAIN CHANGE SPEED BOX.

Joint between top and bottom (Fig. 26).

(iv) WINCH WORM CASING :

- (a) Joint between top and bottom.
- (b) Wormshaft cover.

(v) DRAIN PLUGS, LEVEL PLUGS AND FILLER PLUGS :

- (a) Main gearbox.
- (b) Auxiliary gear box (Fig. 27).
- (c) Change speed box (Fig. 26).
- (d) Winch worm casing. Filler plug and level plug.

(C) INSPECT FOR CRACKS :

- (i) Main gearbox.
- (ii) Auxiliary gearbox.
- (iii) Change speed box.
- (iv) Winch worm drive box.

(D) INSPECT OIL SEALS FOR LEAKS :—

(i) MAIN GEARBOX :

- (a) Mainshaft.
- (b) Spherical bush for change speed shaft at front of selector-casing.

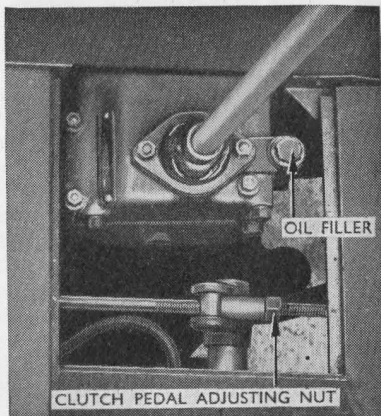

Fig. 26. Access to Change Speed Box and Clutch Pedal Adjuster.

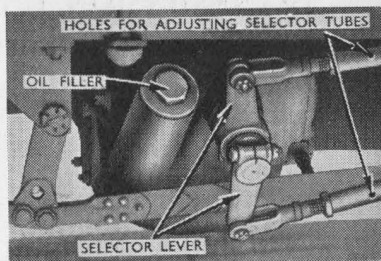

Fig. 27. Auxiliary Gearbox Selector Rods and Oil Filler.

- (ii) **AUXILIARY GEARBOX :**
 (a) Mainshaft at front.
 (b) Front axle drive shaft at front.
 (c) Winch drive shaft at front.
 (d) Output shaft at rear.
- (iii) **CHANGE SPEED BOX :**
 Spherical bush for change speed shaft at rear.
- (iv) **WINCH WORM CASING :**
 Drive shaft bearing.
- (E) **LUBRICATION.**
 Inspect oil level and top up if necessary, to correct level, using oil C.600.
- | | |
|----------------------------|---|
| (i) Main gearbox | } Up to top mark on dipstick (carried in tool box). One side of dipstick is marked "main gearbox" and the other "auxiliary gearbox." For access to the main gearbox, lift front trap in body floor. |
| (ii) Auxiliary gearbox | |
| (iii) Change speed box .. | Should not be more than half full (see page 5). Access to plug by lifting floor trap in driver's cab. (Fig. 26). |
| (iv) Winch worm casing .. | Remove filler plug from top of casing, also level plug from nearside of casing, then fill to level of level plug hole. |
| (v) Clutch withdrawal race | This is a periodical attention (see page 24).
Use oil can with 30 H.D. on all gearbox control fork ends. |
- (F) **REPORT DEFECTS.**

TASK NO. 12

TRANSMISSION UNIVERSAL JOINTS AND AXLES.

- (A) **TRANSMISSION.**
- (i) Clean universal joints and examine for damage.
There are 8 universal joints with 2 types of couplings :
- (a) Inter-gearbox propeller shaft, one fixed and one sliding A.E.C. type coupling.
- (b) Rear axle propeller shaft, one fixed and one sliding Hardy Spicer type coupling.
- (c) Front axle propeller shaft, one fixed and one sliding Hardy Spicer type coupling.
- (d) Winch drive propeller shaft, two sliding type A.E.C. couplings.
Check all nuts and studs for tightness and report any loose or missing, including split pinned nuts around coupling flanges.

- (ii) Lubricate Universal joints.

There are 11 lubrication points (*Lubrication Chart Reference No. 7*) which require attention with the oil gun, using oil C.600. On Hardy Spicer joints a small relief valve is fitted to the centre of the star piece. When oil appears here, the coupling is full.

With A.E.C. couplings, a plug is provided opposite the lubricator. Remove this plug and force oil C.600 through the lubricator until it appears at the plug hole, then replace the plug.

(B) FRONT AND REAR AXLES.

- (i) Clean and examine front and rear axle casings for cracks or other damage.
- (ii) Examine all nuts for tightness.
- (iii) Examine "U" bolts for tightness, look for signs of movement between spring and axles, and report (*Fig. 28*).
- (iv) Examine joints for oil leaks:—

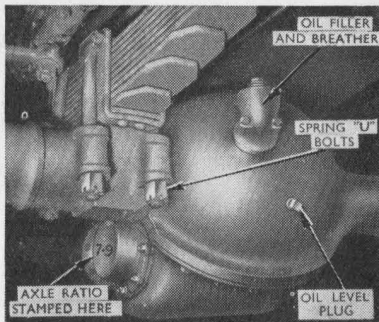

Fig. 28. Front Axle Oil Filler and Level Plug.

Front Axle (*Figs. 15 and 28*).

- (a) 3 bearing housing joints behind propeller shaft coupling flange.
- (b) 2 covers, 1 at each end of helical pinion shaft.
- (c) Joint between axle pot and reduction gear casing.
- (d) Filler plug elbow joint.
- (e) Level plug in front of axle pot.
- (f) Drain plug on nearside of reduction gear casing.
- (g) Signs of leakage of oil from the escape holes in the hubs (*Fig. 39*).

This leakage must be reported at once as it indicates oil leaking to the brake linings.

Rear Axle (*Fig. 29*).

- (a) 2 bearing housing joints behind the propeller shaft coupling.
- (b) 2 covers, 1 at each end of helical pinion shaft.
- (c) Joint between axle pot and drive assembly.
- (d) Filler plug joint on top of axle casing at the nearside.
- (e) Oil level plug at rear of axle casing.
- (f) Drain plug at bottom of axle casing.
- (g) Hub cap.
- (h) Signs of leakage of oil from brake drums.

This must be reported at once as it will indicate a defective packless gland in the axle casing.

- (v) CHECK LEVEL OF OIL IN FRONT AND REAR AXLE CASINGS AND REPLENISH IF NECESSARY :

(a) FRONT AXLE.

The casing should contain oil C.600 up to the level of the level plug hole (see Fig. 28). See that the breather on the filler plug is free from obstruction. (*Lubrication Chart Reference No. 32*).

- (b) Lubricate with oil C.600 through the lubricators on top of the front axle swivel pins. (*Lubrication Chart Reference No. 5*).

- (c) Vehicles fitted with "RZEPPA" Universal Joints to the front wheel drive are provided with a lubricator in each front wheel hub cap. (*Lubrication Chart Reference No. 38*).

(d) REAR AXLE.

The casing should contain oil C.600 up to the level of the level plug hole (see Fig. 29). See that the breather on the filler plug is free from obstruction. (*Lubrication Chart Reference No. 32*).

- (e) Lubricate with oil C.600 through the lubricators in each hub.

- (C) REPORT DEFECTS. (*Lubrication Chart Reference No. 3*).

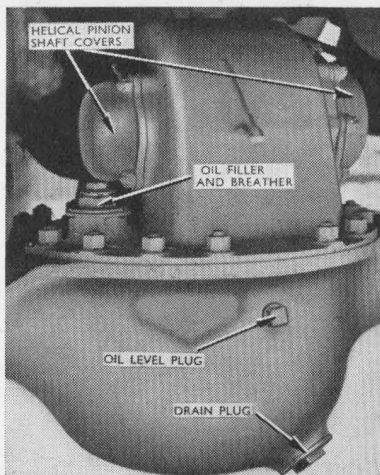

Fig. 29. Rear Axle Oil Filler and Drain Plug.

TASK NO. 13

CHASSIS AND ROAD SPRINGS.

(A) CHASSIS FRAME.

- (i) Check all nuts and bolts on chassis frame for tightness.
 (ii) Examine sidemembers and crossmembers for damage and cracks.

- (iii) Clean draw bar springs and hooks and check for broken leaves or other damage.

Check all nuts for tightness.

- (iv) Lubricate towing hook catches. One point on each hook, using gun and oil C.600.

(Lubrication Chart Reference No. 19).

(B) ROAD SPRINGS.

- (i) Clean the 4 road springs and examine for broken or distorted leaves. **Jack up the frame until the wheel is off the ground, clean the sides and the bottom of the spring and paint the leaves with old engine or gear oil, which will work into the leaves in service.**

- (ii) Check all spring clip bolts for tightness. **These nuts are split pinned.**

- (iii) Examine nuts on shackle pins and clamp bolts for signs of slackness. **These nuts are split pinned.**

- (iv) Lubrication.

Use gun and oil C.600. The numbers in brackets refer to location of lubricator on lubrication chart at end of book.

Item	Location	Number of lubricators
Front Spring Pins	(8)	2
" " Shackles	(9)	2
Rear Spring Front Pins	(10)	2
" " Shackles	(11)	2

(C) REPORT DEFECTS.

TASK NO. 14

BODY.

(A) CAB :—

- (i) EXAMINE MOUNTING ON FRAME AND CHECK SECURITY OF BOLTS FOR TIGHTNESS.

- (ii) EXAMINE FOR WEAR, DAMAGE AND CORRECT OPERATION :—

(a) Doors.

(b) Glass windows (for cracks ; check tightness and correct operation in opening).

- (c) Driver's and passengers' seats (for adjustability and worn cushions).
- (d) Driving mirrors and brackets.
- (e) Serviceability of chain attached to radiator filler cap.
- (f) Tool lockers.
- (g) Gas detector tray.

(B) BODY :—

- (i) Examine mounting on frame and check securing bolts for tightness.
- (ii) Examine mounting of mudguards for security.
- (iii) Examine for wear, damage and correct operation :—
 - (a) Doors. **One in each side.**
 - (b) Seats. **For worn cushions.**
 - (c) Floor traps.
 - (d) Tail board, chains and pins.
 - (e) Lockers.
 - (f) Woodwork and fabric on body.
 - (g) Ammunition stowage.
 - (h) Kit racks.
 - (i) Straps, ropes, eyelets and "lift the dot" fasteners on side curtains.

(C) LUBRICATION.

Lubricate all locks, catches and hinges, including floor traps.
Use oil can and oil 30 H.D.

(D) REPORT DEFECTS.

TASK NO. 15

BRAKE SYSTEM.

A) INSPECT MOUNTING FOR LOOSE NUTS :—

- (i) Servo and Hydraulic Master Cylinder (*see Figs. 30 and 31*).
- (ii) Brake cylinders—one for each wheel.
- (iii) Trailer brake cylinder on rear of chassis.

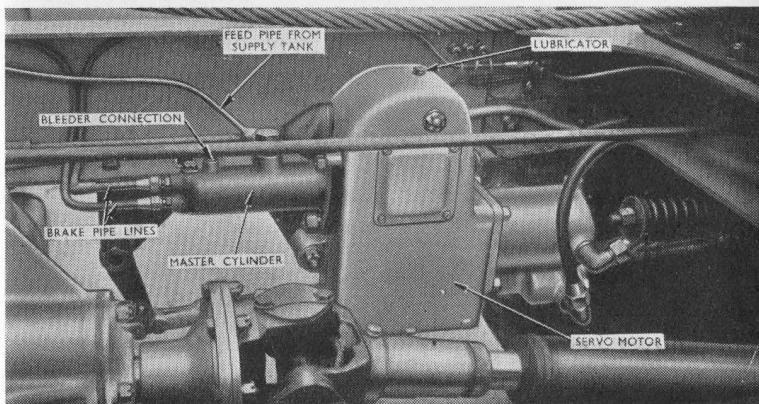

Fig. 30. Westinghouse Servo and Lockheed Master Cylinder.

- (iv) Warner brake controller on dash or O.S. chassis frame.
- (v) Warner brake coupling socket on rear of chassis.
- (vi) Air compressor on gearbox.
- (vii) Air storage tank on nearside chassis member.
- (viii) Tyre inflater on nearside chassis member.
- (ix) Anti-freezer on nearside chassis member.
- (x) Brake governor or composite valve on nearside.

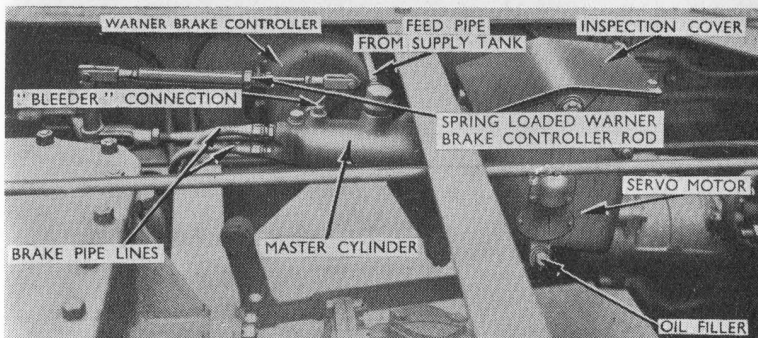

Fig. 31. Clayton-Dewandre Servo and Lockheed Master Cylinder.

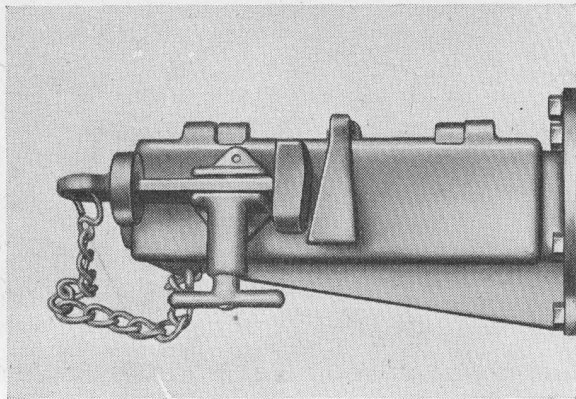

Fig. 32. Trailer Brake Cable Connector Box with Retaining Catch Parked in Carrier.

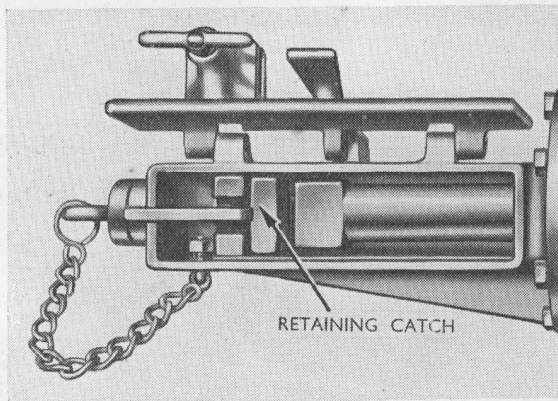

Fig. 33. Trailer Brake Cable Connector Box with Retaining Catch in Lock Position.

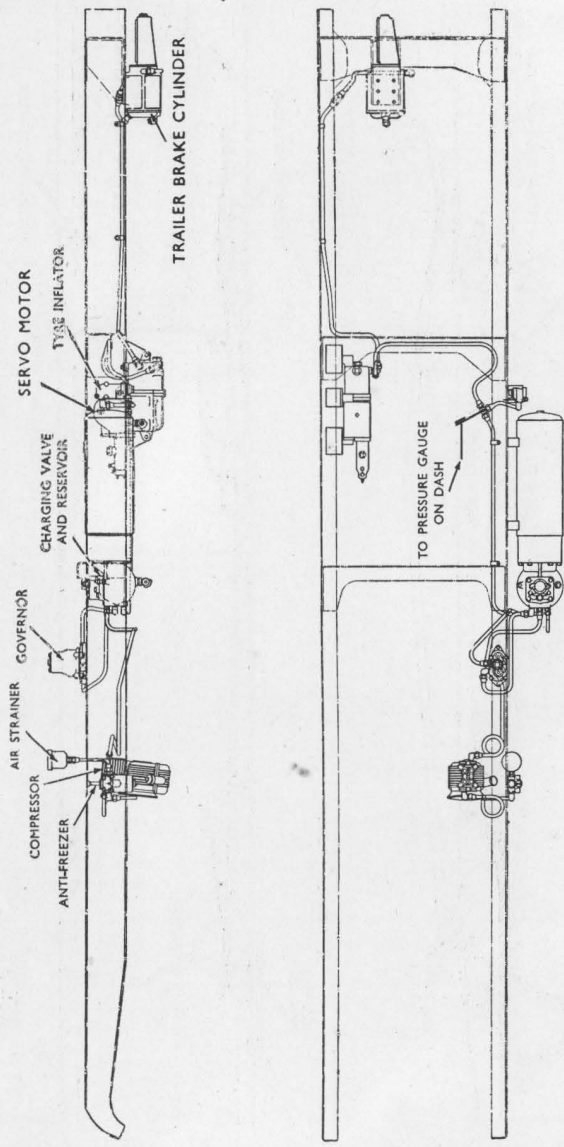

Fig. 34. Brake air pressure system (Westinghouse).

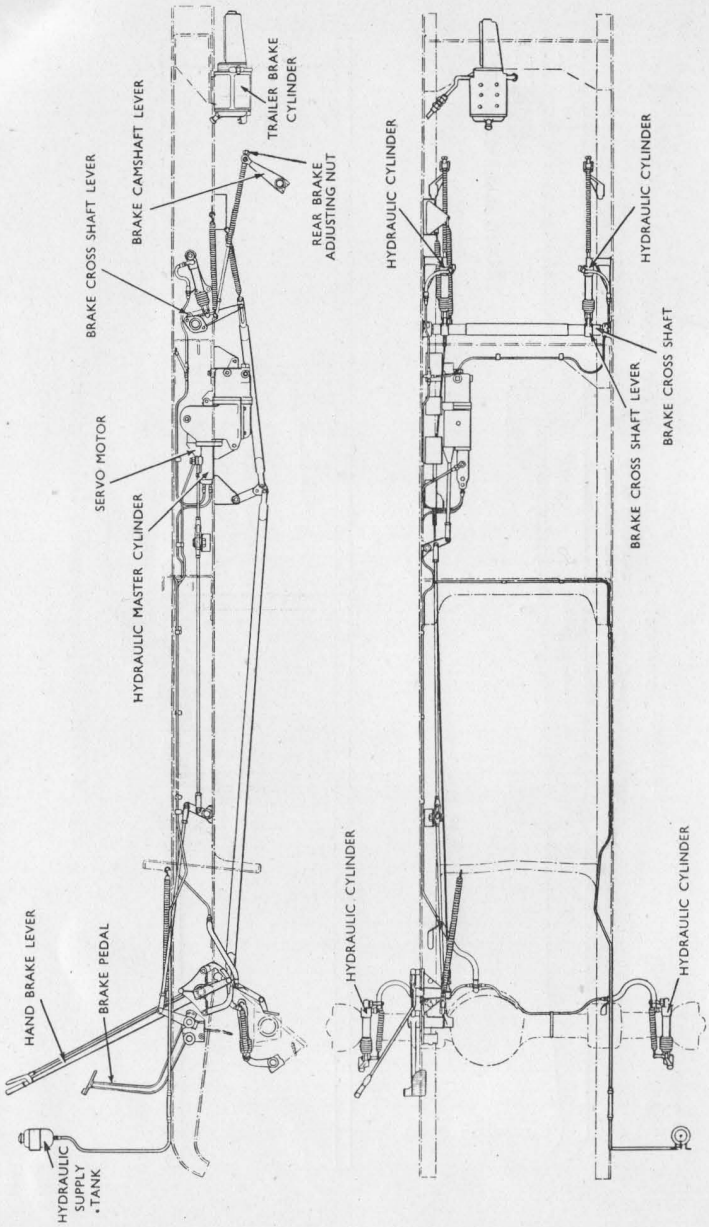

Fig. 35. Arrangement of Brake Gear (Hydraulic and Mechanical Rigging).

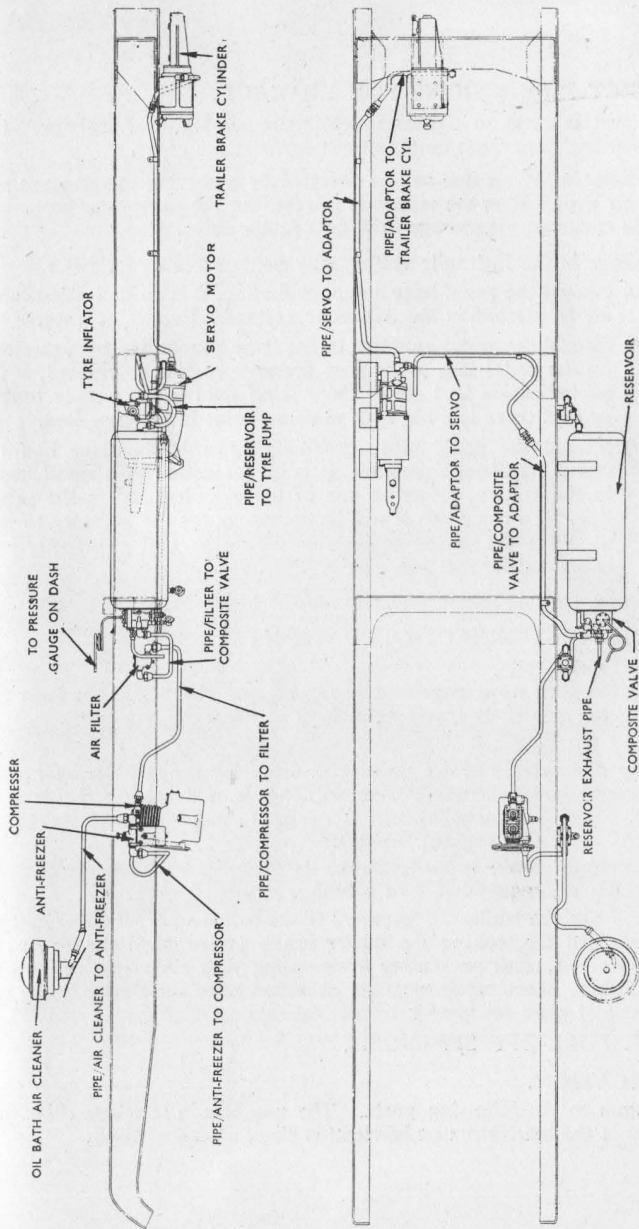

Fig. 36. Brake Air Pressure System (Clayton-Dewandre).

(B) INSPECT PIPE UNIONS FOR LEAKAGE.

Do not attempt to tighten unless there are signs of leakage. In tightening, care must be taken not to twist the pipes.

(i) Leakage in the air line can be detected by observing the pressure on the air gauge when the vehicle is at rest, but the cause may be leaky drain cocks on the storage tank or a faulty valve.

(ii) Leakage in the hydraulic system may be detected as follows :—

(a) Should the pedal have a spongy feeling, it is an indication that air is present in the hydraulic system. Report at once.

(b) Should the pedal go down to the floor boards and by pumping on the pedal it is found that pressure cannot be created, it is an indication that either there is no fluid in the supply tank, or that there is a big leak at some point in the pipe line.

(c) Should the pedal move gradually towards the floor boards under continuous pressure, it is an indication of a small leak in the system, either at one of the cylinders, or in the pipe line. To trace this it will be necessary for the pressure to be kept on the pedal while the pipe line and cylinders are examined for leakage. Report at once.

(iii) Examine flexible hose connections to the brake cylinders.

(C) CHECK FOR CORRECT OPERATION :—

(i) **HAND BRAKE.**

Examine pawl for engagement in ratchet and check that the lever is not at the end of its travel when fully applied.

(ii) **FOOT BRAKE.**

Apply and release brake pedal and listen for air release. Obtain assistance and, with engine running, apply and release the brake pedal while watching operation of each brake cylinder in turn (including trailer brake cylinder).

Should the brake pedal touch the floorboards, or if two strokes of the pedal are required to give a brake, report at once.

Note.—On the trailer air pressure brake cylinder, a retaining catch is provided for locking the trailer brake piston when the trailer is disconnected, thus preventing it operating with each application of the brakes. This catch must be detached when the trailer brake is in use and when testing for correct operation (*see Figs. 32 and 33*).

(iii) **ALL PULL-OFF SPRINGS.**

(D) LUBRICATION.

Apply gun to the following parts. The numbers in brackets refer to location of the lubricators on lubrication chart at end of book.

Part	Location	Lubricant	No. of Lubricators
Front Brake Camshaft ..	(4)	Oil C.600	1 on each
Rear Brake Camshaft ..	(4)	Oil C.600	1 on each
Brake Cross Shaft ..	(24)	Oil C.600	2
Hand Brake Lever Pivot ..	(22)	Oil C.600	1
Brake Pedal Shaft ..	(21)	Oil C.600	1
Trailer Brake Cylinder (PistonRod)	(14)	Oil C.600	1
Servo Motor (Westinghouse only)	(23)	Oil C.600	1

The Clayton-Dewandre Servo must be topped up to height of oil level plug, with oil 30 H.D. (see Fig. 31) (*Lubrication Chart Reference No. 26*).

The Trailer Brake Cylinder must be topped up with oil 30 H.D. to height of the filler plug (*Lubrication Chart Reference No. 33*).

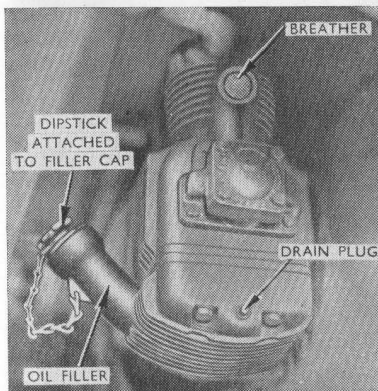

Fig. 37. Air Compressor.

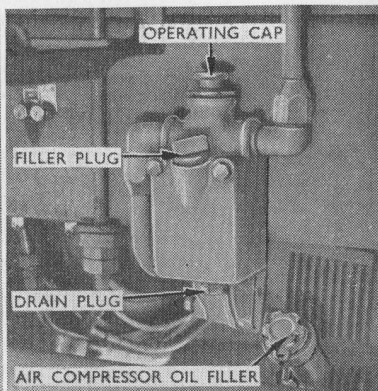

Fig. 38. Anti-freezer.

In addition to the above, all brake lever fork ends, the hand brake ratchet and pawl and pawl release trigger, also hinged lid of Warner brake coupling socket on rear of chassis, must be oiled with oil can using oil 30 H.D.

(E) AIR COMPRESSOR. (Fig. 37).

- (i) With engine running, inspect air compressor cylinder head and covers for leaks, also see that breather is free from obstruction.

(ii) Lubrication.

Top up with oil 30 H.D. to full mark on dipstick. (*Lubrication Chart Reference No. 2.*)

(F) ANTI-FREEZER. (*Fig. 38.*)

Check fluid level (if in use) (*see page 16.*)

“I.M.S. Substitute” or “Methanol” only to be used.

Fill to level of the filler plug. Check security of drain plug.

(G) DRAIN CONDENSATE.

(a) Air Storage Tank. (*See Figs. 7 and 8.*) This is a daily task, *see page 23.*

(b) Tyre Inflator. Remove drain plug at base, refit and tighten securely.

Do not drain the trailer brake cylinder as this is charged with oil.

(H) HYDRAULIC SUPPLY TANK (ON FRONT DASH) (*see Fig. 35.*)

Top up with W.D. Hydraulic Brake Fluid No. 3 to within $\frac{1}{2}$ in. of the top. (*Lubrication Chart Reference No. 27.*)

TASK NO. 16

TYRES AND TOOLS.

(A) CHECK TYRE PRESSURES.

This is dealt with under heading “Periodical Attention,” page 22.

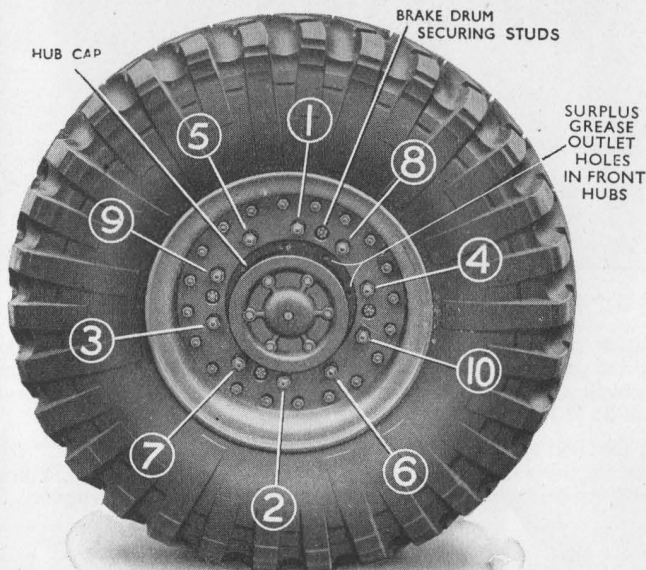

Fig. 39.
Sequence of Tightening Wheel Studs.

Note.—See that any new tyres fitted are recorded in AB412, with date, speedometer reading and serial number of old and new tyres.

When removing a wheel, be careful to unscrew the 10 inner nuts and NOT the 20 outer ones (which are painted red).

- (B) CHECK WHEEL MOUNTING AND TIGHTEN IF NECESSARY. When tightening wheel stud nuts, give each a few turns only at a time in the order shown in Fig. 39, until all are uniformly tight.
- (C) REMOVE OIL, TAR, FLINTS AND STONES FROM TYRES. Report undue or uneven wear, badly cut tyres and defective valves or fittings.
- (D) CHECK TOOLS, EXCHANGE DAMAGED TOOLS, MAKE GOOD DEFICIENCIES. Check against A and B schedules.
- (E) SEE THAT FIRE EXTINGUISHER IS FULL AND READY FOR USE. Place thumb over the outlet, turn handle to the left and operate the plunger just enough to feel that pressure is being applied. Lock handle by turning to the right, then shake extinguisher backwards and forwards to expel the small amount of charge released during the test. Check bracket and tighten fixing if necessary.
- (F) REPORT DEFECTS.

SPECIAL TOOLS.

WAR OFFICE SCHEDULE "A."

Description	No. Off
Brace for Wheel Mounting Nuts	1
19 m/m Spanner/Single Ended	1
22 m/m Spanner/Single Ended	1
Lubrication Gun	1
*Box Spanner for Connecting Rod and Cylinder Head ..	1
Spanner for Engine Drain	1
Flexible Air Pipe for Tyre Inflation	1
Tyre Valve "Inside" Tool	1
*Injector Complete	1
Padlock with 2 Keys	6
Box Spanner with Tommy Bar for Shell Runners and Outer Wheel Nuts	3
Key for Brake Air Storage Tank and Tyre Valve	1
*Dipstick/Main and Auxiliary Gearbox	1
Tool Box/Rough Case	1

* Early vehicles only.

STANDARD TOOLS.

WAR OFFICE SCHEDULE "B."

Description	No. Off
Tyre Pressure Gauge	1
Tool Roll	1
Insulation Tape and Container	1
20 I.W.G. Galvanised Iron Wire	15 Ft.
Headlamp Bulb	1
Side Lamp Bulb	1
Tail Lamp Bulb	1
Bulb Container	1
Inspection Lamp	1
Engine Oil Funnel	1
Oil Can	1
Hammer and Shaft	1
Pliers	1
Screw Driver 11"	1
Screw Driver 7"	1
Spanner (Box) $\frac{1}{4}$ " and $\frac{5}{16}$ "	1
Spanner (Box) $\frac{5}{16}$ " and $\frac{3}{8}$ "	1
Spanner (Box) $\frac{7}{16}$ " and $\frac{1}{2}$ "	1
Spanner (Box) $\frac{9}{16}$ " and $\frac{5}{8}$ "	1
Tommy Bar	1
Spanner (Double Ended) $\frac{1}{8}$ " and $\frac{3}{16}$ "	1
Spanner (Double Ended) $\frac{1}{4}$ " and $\frac{5}{16}$ "	1
Spanner (Double Ended) $\frac{3}{8}$ " and $\frac{7}{16}$ "	1
Spanner (Double Ended) $\frac{1}{2}$ " and $\frac{9}{16}$ "	1
Spanner (Double Ended) $\frac{5}{8}$ " and $\frac{3}{4}$ "	1
Spanner (Double Ended) $\frac{11}{16}$ " and $\frac{13}{16}$ "	1
Spanner (Adjustable) 4"	1
Spanner (Adjustable) 11"	1
Lifting Jack and Handle	1
Fire Extinguisher	1

RUNNING FAULTS AND GENERAL HINTS.

If the Engine stops or runs unevenly it may be due to an air lock in the fuel system.

Remedy :—

- (i) Vent the fuel system (*see page 34*).
- (ii) If unsuccessful, check that :—
 - (a) There is fuel in the fuel tank (if main tank is empty, change to reserve).
 - (b) No pipes are leaking.
 - (c) The vent pipe is not choked (*see Fig. 18*).
 - (d) Filter on lift pump is clean (*see page 34*), and that the joint washer at top of filter bowl is in good condition and the thumb screw at base of the filter bowl is perfectly tight.
- (iii) Vent the fuel system after checking as above.

Do not rely on the reserve fuel tank always having 6 gallons, as on cross country work the fuel in the reserve tank is liable to splash into the main tank.

Faulty Injection.

Any troubles experienced with injection will probably be accompanied by one or more of the following (report immediately) :—

- (i) Heavy blue-white smoke in the exhaust when the engine is hot and pulling on load.
- (ii) Misfiring ; listen at the exhaust tail pipe.
- (iii) Pronounced knocking in the affected cylinder.
- (iv) Loss of power.
- (v) A broken injector pipe. **In an emergency bend the broken pipe over so as to throw clear of the engine, and let the fuel run to waste. Do not block up the broken pipe.**

Damaged Accelerator Pedal.

Use the hand throttle lever, or if necessary in an emergency, have a second man operate the control lever attached to fuel pump.

Damaged Radiator Tubes.

In an emergency, if the tubes are broken, remove the guard and pinch the ends of the broken tubes together.

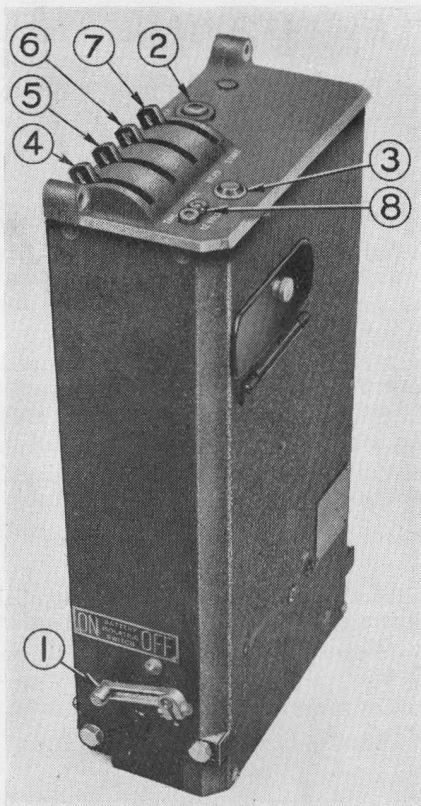

KEY TO INDEX NUMBERS.

- | | |
|----------------------------|--------------------------------|
| 1. Battery Cut-out Switch. | 5. Side Lamp Switch. |
| 2. Starter Button. | 6. Head Lamp Switch. |
| 3. Dynamo Indicator Light. | 7. Starting Switch. |
| 4. Tail Lamp Switch. | 8. Inspection Lamp Connection. |

Fig. 40. Electrical Control Unit (Simms).

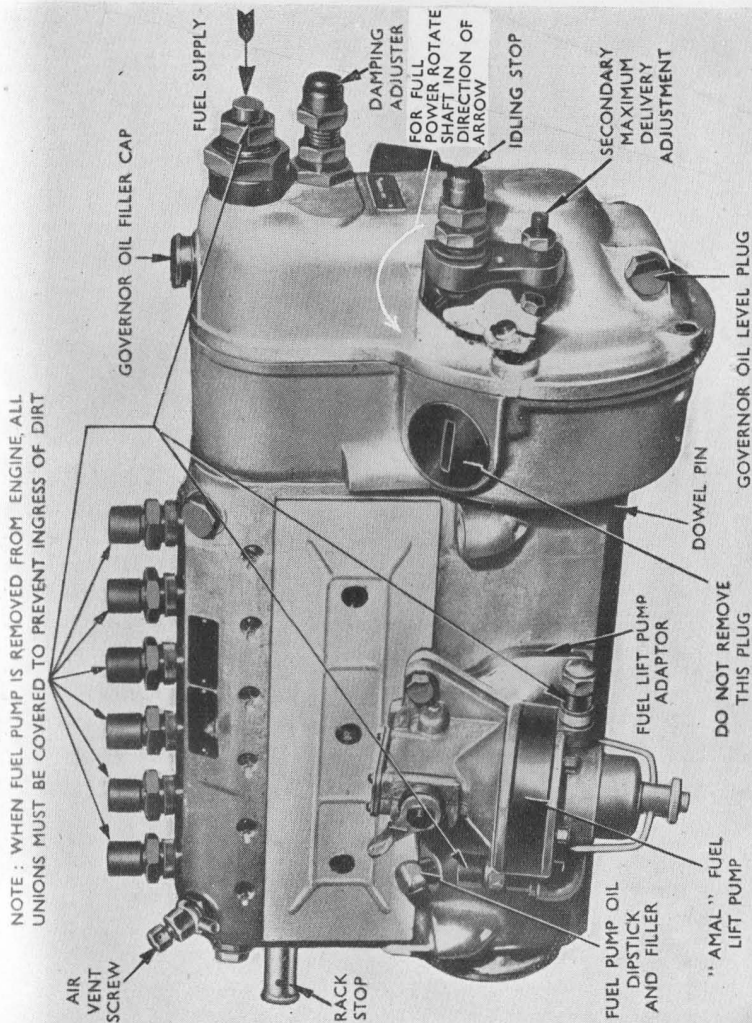

Fig. 41. Fuel Injection Pump and Governor (C.A.V.).

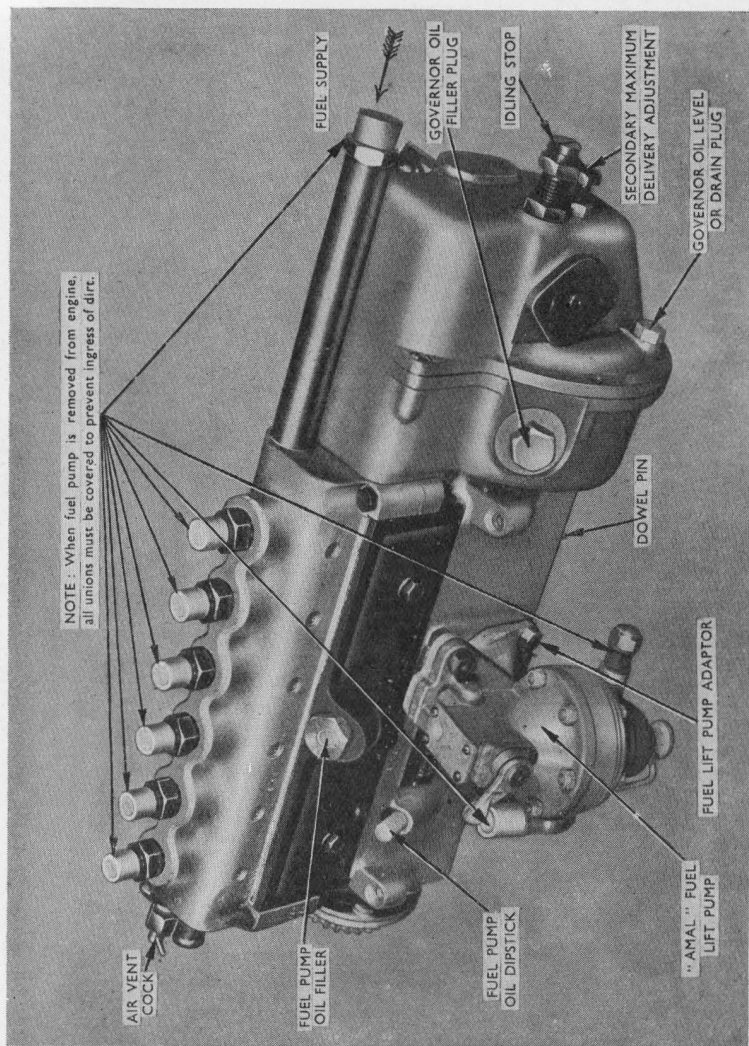

Fig. 42. Fuel Injection Pump and Governor (Simms).

NOTES.

NOTES.

NOTES.

NOTES.